



**GETZ EQUIPMENT
PART NO.: 3G58836
MODEL: SGL SV 50 PR
VACUFILL SYSTEM**



2320 Lakecrest Drive, Pekin IL 61554
PH. (888) 747-4389 • Fax (309) 495-0625
Website: www.getzequipment.com

LIMITED WARRANTY

Getz Equipment Innovators warrants its products, and component parts of any product manufactured by Getz Equipment Innovators, to be free from defects in material and workmanship for a period of twelve (12) months from the date of purchase. During the warranty period, any such defects will be repaired or the defective parts replaced **(at Getz Equipment Innovators' option)**. The warranty does not cover defects resulting from modification, alteration, misuse, exposure to corrosive conditions, extremely high temperatures, improper installation or maintenance. Warranties on component items not manufactured by Getz Equipment Innovators are provided by others whose warranty, evaluation and judgment will be final.

All implied warranties, including, but not limited to, warranties of fitness for purpose and merchantability, are limited to the time periods as stated above. In no event shall Getz Equipment Innovators be liable to incidental or consequential damages. Some states do not allow limitations on how long an implied warranty lasts or the exclusions or limitation of incidental or consequential damages, so that the above limitations or exclusions may not apply to you. Getz Equipment Innovators neither assumes nor authorizes any representative or other person to assume for it any obligation or liability other than as expressly set forth herein.

Mobile Service Vehicles:

The warranty does not cover:

- Defects in the chassis and or power unit
- Defects in separately manufactured products not produced by Getz Equipment Innovators
- Deterioration due to normal wear, tear, and exposure
- Repairs made necessary by negligent use, misuse, abuse, loading the service vehicle beyond its gross vehicle weight limitations, accident, acts of God, or other contingencies beyond the control of Getz Equipment Innovators.
- Repairs deemed necessary by reason of the failure to follow ordinary maintenance procedures.
- Repairs deemed necessary by reason of alterations done without Getz Equipment Innovators' written approval.

Warranty Service:

- All warranty repairs will be performed by Getz Equipment Innovators in Pekin, IL, unless otherwise authorized by Getz Equipment Innovators.

Freight:

- Getz Equipment Innovators will not be liable for shipping or transportation charges to or from customer's location.

This warranty gives you specific legal rights, and you may also have other rights which vary from state to state. To obtain performance to the obligation of the warranty, write to Getz Equipment Innovators, 2320 Lakecrest Drive, Pekin IL 61554, USA for instructions.



!!WARNING!!

SEVERE DAMAGE AND/OR INJURY MAY RESULT

50 & 100 # CAPACITY VACUFILLS:
DO NOT DISCHARGE ANY EXTINGUISHER
CYLINDER EXCEEDING 195 PSI AND NOT
EXCEEDING 30 POUNDS IN AGENT WEIGHT.

150 # CAPACITY VACUFILLS:
DO NOT DISCHARGE ANY EXTINGUISHER
CYLINDER EXCEEDING 195 PSI WITHOUT THE
USE OF GETZ EQUIPMENT P/N 59745,
WHEELED SYSTEM DISCHARGE ASSEMBLY,
INSTALLED.

FAILURE TO INSTALL AND OPERATE
EQUIPMENT ACCORDING TO THE
GUIDELINES PUT FORTH IN THE
INSTRUCTION MANUAL SHALL VOID
WARRANTY.

PART #58836

"NIFTY FIFTY"

GETZ SGL SV 50 PR VACU-FILL SYSTEM

TABLE OF CONTENTS

PAGE #

| | |
|----------|--|
| 1 | GETZ SGL SV 50 PR VACU-FILL SYSTEM |
| 2 | PARTS LIST |
| 3 | DRAWING #1 - GENERAL ARRANGEMENT |
| 4 | DRAWING #2 - DISCHARGE ASSEMBLY DETAIL |
| 5 | DRAWING #3 - CONSOLE AND FILTER ASSEMBLY |
| 6 | DRAWING #4 - CONSOLE LID INTERIOR |
| 7 | DRAWING #5 - CONSOLE BODY INTERIOR |
| 8 | ASSEMBLY INSTRUCTIONS |
| 9 | PROCEDURE FOR DISCHARGING FIRE EXT. |
| 10 | PROCEDURE FOR FILLING FIRE EXT. |
| 11 | TROUBLE SHOOTING & SERVICE AIDS |
| 12 | TROUBLE SHOOTING & SERVICE AIDS - CONT. |
| 13 | RECOMMENDED MAINTENANCE KIT |

GETZ SGL SV 50 PR

VACU-FILL SYSTEM

MOTIVE POWER SOURCE

AIR COMPRESSOR
COMPRESSED AIR
NITROGEN
CO2 VAPOR

CUSTOMER MUST REMOVE THE SIPHON TUBE FROM THE SUPPLY VALVE OF THE LIQUID CO2 TANK TO HAVE VAPOR.

To get the maximum on your vacu-fill. The operating input pressure may range from 60 to 90 PSI. To set your regulator for best results, take the white vacuum line (#5) out of connector (#35) on the bottom left outside console. Turn the on-off valve (#19) to the "ON" position and put your finger over connector (#35). Then, adjust regulator up or down, whichever is needed, so that you have the maximum on your gauge.

CYCLE TIMES TO EXHAUST (OR EMPTY)

5 LB EXTINGUISHER (2.27 KG) = 15 SECONDS
10 LB EXTINGUISHER (4.50 KG) = 25 SECONDS
20 LB EXTINGUISHER (9.00 KG) = 30 SECONDS

CYCLE TIMES TO FILL

5 LB EXTINGUISHER (2.27 KG) = 20 SECONDS
10 LB EXTINGUISHER (4.50 KG) = 30 SECONDS
20 LB EXTINGUISHER (9.00 KG) = 60 SECONDS

SHIPPING SIZE OF CONTAINER

SGL SV 50 PR - 13" X 13" X 25 1/4"

WARNING: MUST WEAR SAFETY GLASSES

PARTS LIST

| <u>DRAWING #</u> | <u>PART #</u> | <u>DESCRIPTION</u> |
|------------------|---------------|--------------------------------|
| 1 | 3G58838 | POWDER RECOVERY LID 50# |
| 2 | ##### | CONSOLE BRACKET |
| 3 | 3G58872 | DCH ASY V-50 PR |
| 4 | 1G0049 | MTL NYCOIL 3/8" WH |
| 5 | 1G0048 | MTL NYCOIL 1/4 WH X 7' |
| 6 | 1G0032 | MTL VINYL TUBE 1/2 CLR X 9' |
| 7 | 1G0091 | CONE FILL |
| 8 | 3G0092 | SV1 CONSOLE COMPLETE |
| 9 | XXXXX | LID SV1 CONSOLE |
| 10 | XXXXX | BOX CONSOLE SV1 |
| 11 | 1G0207 | STEM FILTER AC-396 |
| 12 | 1G0067 | FLTR WH JAR ASSY |
| 13 | 1G0206 | CAP FLTR |
| 14 | 1G51436 | JAR PLASTIC VACU-FILL |
| 15 | 1G51709 | PIPE UNION PLAS 3/8 BLKHD |
| 16 | 1G0101 | CLAMP PLAS HOPPER OUTLET |
| 17 | 1G0116 | CONN PLAS 1/4 |
| 18 | XXXXX | DECAL LEXAN PANEL SV1 |
| 19 | 3G58649 | VALVE ON-OFF BR SV1 |
| 20 | 1G0120 | PIPE ELB PLAS 1/4ML X 1/4TUBE |
| 21 | 1G51590 | NUT & FERRULE 1/4 PLAS |
| 22 | 1G0021 | VENTURI COMPLETE |
| 23 | 1G51589 | NUT & FERRULE 1/4 BR |
| 24 | 1G0041 | CLAMP OETIKER 3/4 |
| 25 | 1G54039 | FLTR HOPPER LID 50# |
| 26 | 1G51663 | PIPE NIP PLAS 1/2 BARBED |
| 27 | 1G0047 | MTL NYCOIL 1/4 YL |
| 28 | 1G51302 | FASTENER LOCKING CONSOLE |
| 29 | 1G0018 | GAUGE 30MG VACUUM |
| 30 | 1G0200 | PIPE TEE 1/4 X 1/8 FMLE BRANCH |
| 31 | 1G0047 | MTL NYCOIL 1/4 YL |
| 32 | 1G0046 | MTL NYCOIL 1/4 RD |
| 33 | 1G51710 | PIPE UNION RDCR PLAS 3/8 X 1/4 |
| 34 | 1G0049 | MTL NYCOIL 3/8 WH |
| 35 | 1G51233 | CONNECTOR PLAS 1/4FML X 1/4TUB |
| 36 | 1G0011 | BKT FLTR ASY JAR CLP |
| 37 | 1G0017 | FLTR ASY CASTING W/O JAR |
| 38 | 1G51592 | NUT & FERRULE 3/8 PLAS |
| 39 | 1G51653 | PIPE NIP BR 1/4 X 3 1/2 |
| 40 | 1G0205 | GASKET JAR |
| 41 | 1G51789 | SCREEN DCH |
| 42 | 1G51428 | HUB MEYER 3/4 FMLE X FMLE |
| 43 | 1G0308 | PIPE RDCR BR 3/4X1/4 |
| 44 | 1G51624 | PIPE ELB BR 1/4 ST |
| 45 | 1G0042 | VLV BALL 1/4 X 1/4 ML |
| 46 | 1G0075 | BARB HOSE BR 1/2 X 1/2 |
| 47 | 1G0033 | MTL NYLON TUBE DCA1 5/8 - 24" |
| 48 | 1G0076 | BARB HOSE BR 1/2 X 1/4 |
| 49 | 1G0028 | CPLG 1/4 FMLE STR THRU |
| 50 | 1G0025 | CPLG 1/4 X 1/8 ML STR |
| 51 | 3G0014 | FTNG BR FILLER TUBE COMP |
| 52 | 1G51469 | LATCH HOPPER |
| 53 | 1G0159 | CLAMP BROOM |
| 54 | 1G0014 | BRKT RING |

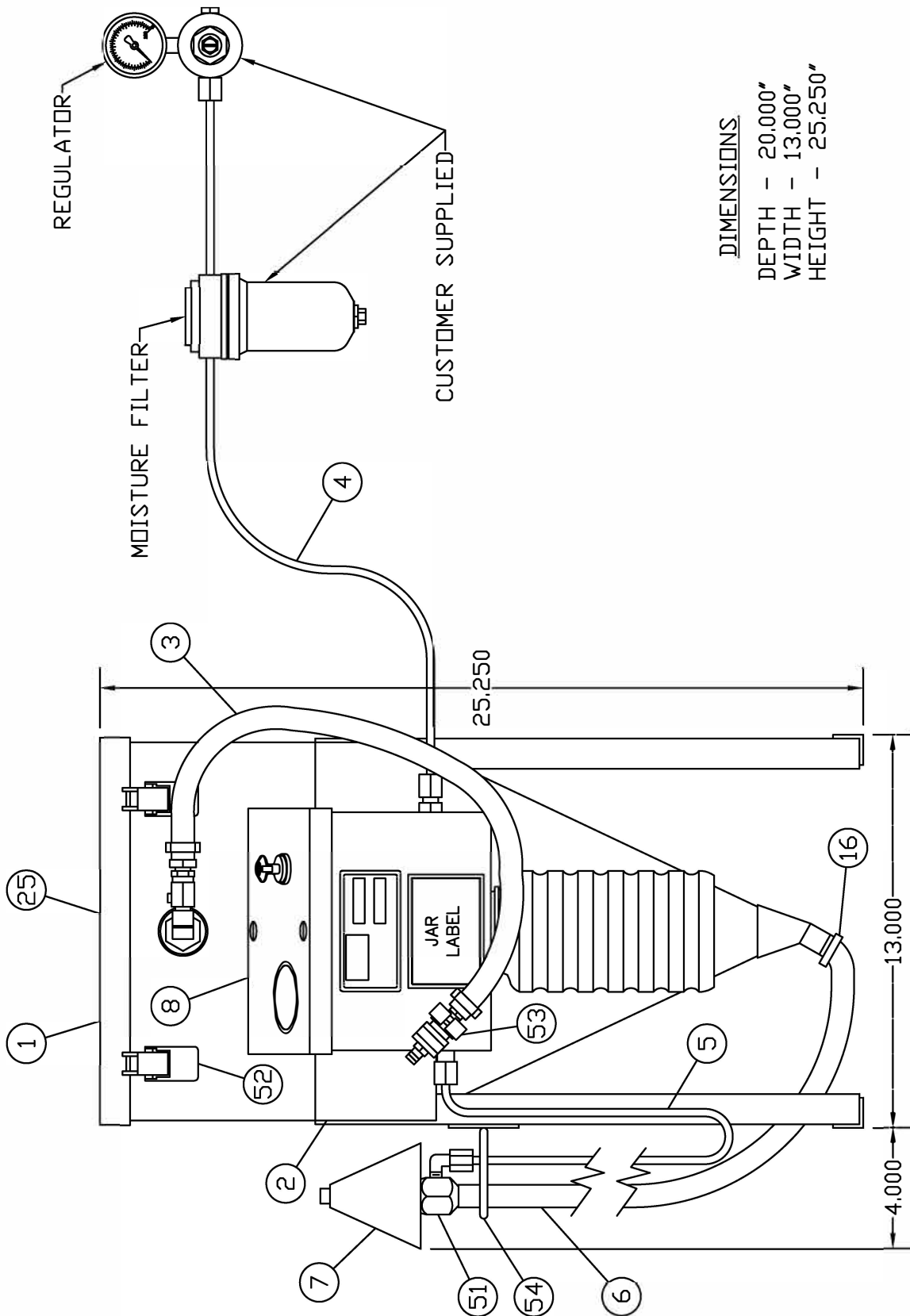

DIMENSIONS

DEPTH - 20.000"
 WIDTH - 13.000"
 HEIGHT - 25.250"

THIS DRAWING IS THE EXCLUSIVE AND CONFIDENTIAL PROPERTY OF GETZ MFG. IT SHALL NOT BE DUPLICATED, USED OR DISCLOSED TO OTHERS WITHOUT THE EXPRESS WRITTEN CONSENT OF GETZ EQUIPMENT

| | | | | | | | |
|---------------------------------------|--|-------------------------------|---------|-------------|--|--------------------|--|
| DRAWING CHANGE | | BY | ECN NO. | MATERIAL | | FINISH | |
| TOLERANCES UNLESS OTHERWISE SPECIFIED | | 2 PL DEC ±.010 3 PL DEC ±.003 | | SCALE NONE | | TITLE SGL SV 50 PR | |
| REV | | | | FRAC. ±.020 | | SHEET NO. 1 OF 5 | |
| | | | | BIN NO. | | DWG. NO. 3G58836-M | |
| | | | | REV. | | * | |



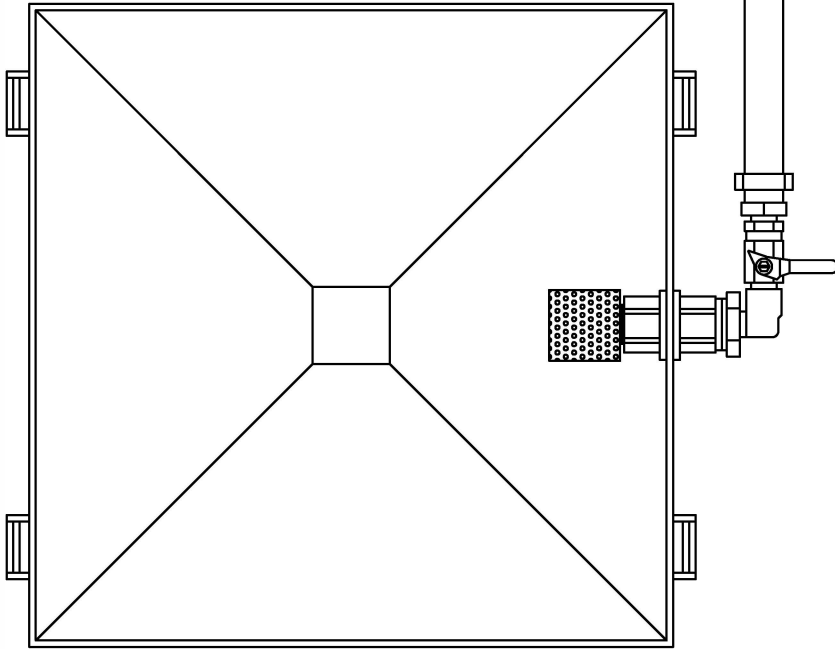

DETAIL A

NOTE:
 IF PART #67 (NYLON REINFORCED HOSE) BECOMES DISCOLORED,
 IT MUST BE REPLACED SO OPERATOR CAN VISUALLY INSPECT
 CHEMICAL.
 REPLACEMENT PART #51557

| | | | | |
|---|-----------------|---|--------------------------|---------|
| THIS DRAWING IS THE EXCLUSIVE AND CONFIDENTIAL PROPERTY OF GETZ MFG. IT SHALL NOT BE DUPLICATED, USED OR DISCLOSED TO OTHERS WITHOUT THE EXPRESS WRITTEN CONSENT OF GETZ EQUIPMENT | | GETZ EQUIPMENT INNOVATORS <small>AN AFFILIATE OF GETZ HOLDINGS</small> | SHEET NO. 2 OF 5 | BIN NO. |
| MATERIAL | FINISH | CK'D K.L.R. | TITLE DCH ASY V-50 PR | |
| DWN BY J.A.L. | DATE 7-20-91 | SCALE 1/4" = 1" | DWG. NO. 58836-2M | |
| TOLERANCES UNLESS OTHERWISE SPECIFIED | | REV. * | | |
| FRAC. ±.020 | 2 PL DEC ±.010 | 3 PL DEC ± .003 | | |

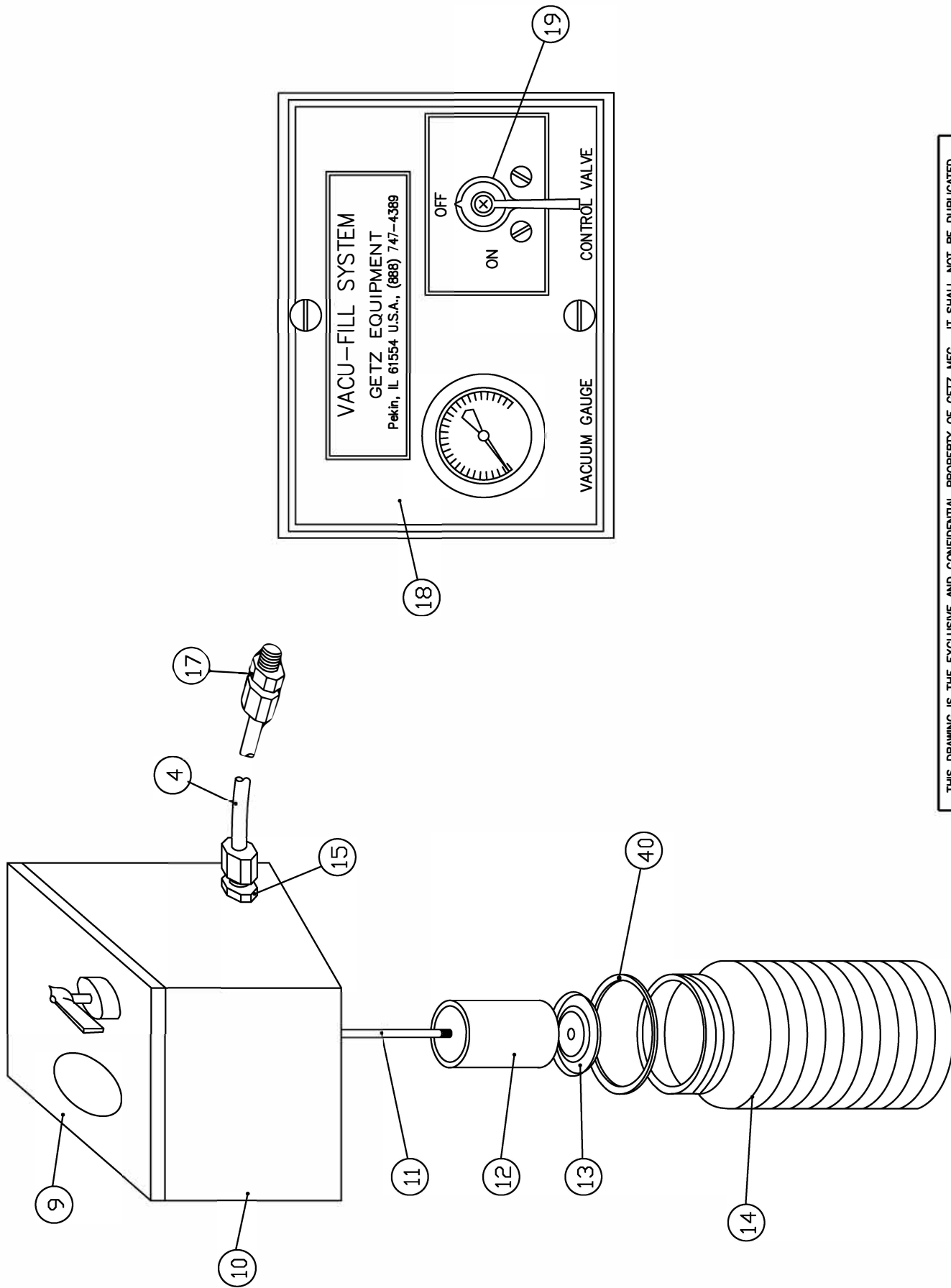

THIS DRAWING IS THE EXCLUSIVE AND CONFIDENTIAL PROPERTY OF GETZ MFG. IT SHALL NOT BE DUPLICATED, USED OR DISCLOSED TO OTHERS WITHOUT THE EXPRESS WRITTEN CONSENT OF GETZ EQUIPMENT

GETZ
EQUIPMENT INNOVATORS

GETZ

VACU-FILL SYSTEM

VACUUM GAUGE

CONTROL VALVE

ON

OFF

VACU-FILL SYSTEM
GETZ EQUIPMENT
Peekin, IL 61554 U.S.A., (888) 747-4389

| | |
|-----------|---------|
| SHEET NO. | BIN NO. |
| 3 OF 5 | |
| DWG. NO. | REV. |
| 58836-3M | * |

| | | | |
|---------------------------------------|----------------|----------------|------|
| MATERIAL | FINISH | | |
| | | | |
| DWN BY | DATE | | |
| R.D.M. | 7-29-04 | | |
| SCALE | TITLE | | |
| 1"=1" | SGL SV 50 PR | | |
| DRAWING CHANGE | BY | ECN NO. | DATE |
| | | | |
| TOLERANCES UNLESS OTHERWISE SPECIFIED | | | |
| FRAC. ±.020 | 2 PL DEC ±.010 | 3 PL DEC ±.003 | |

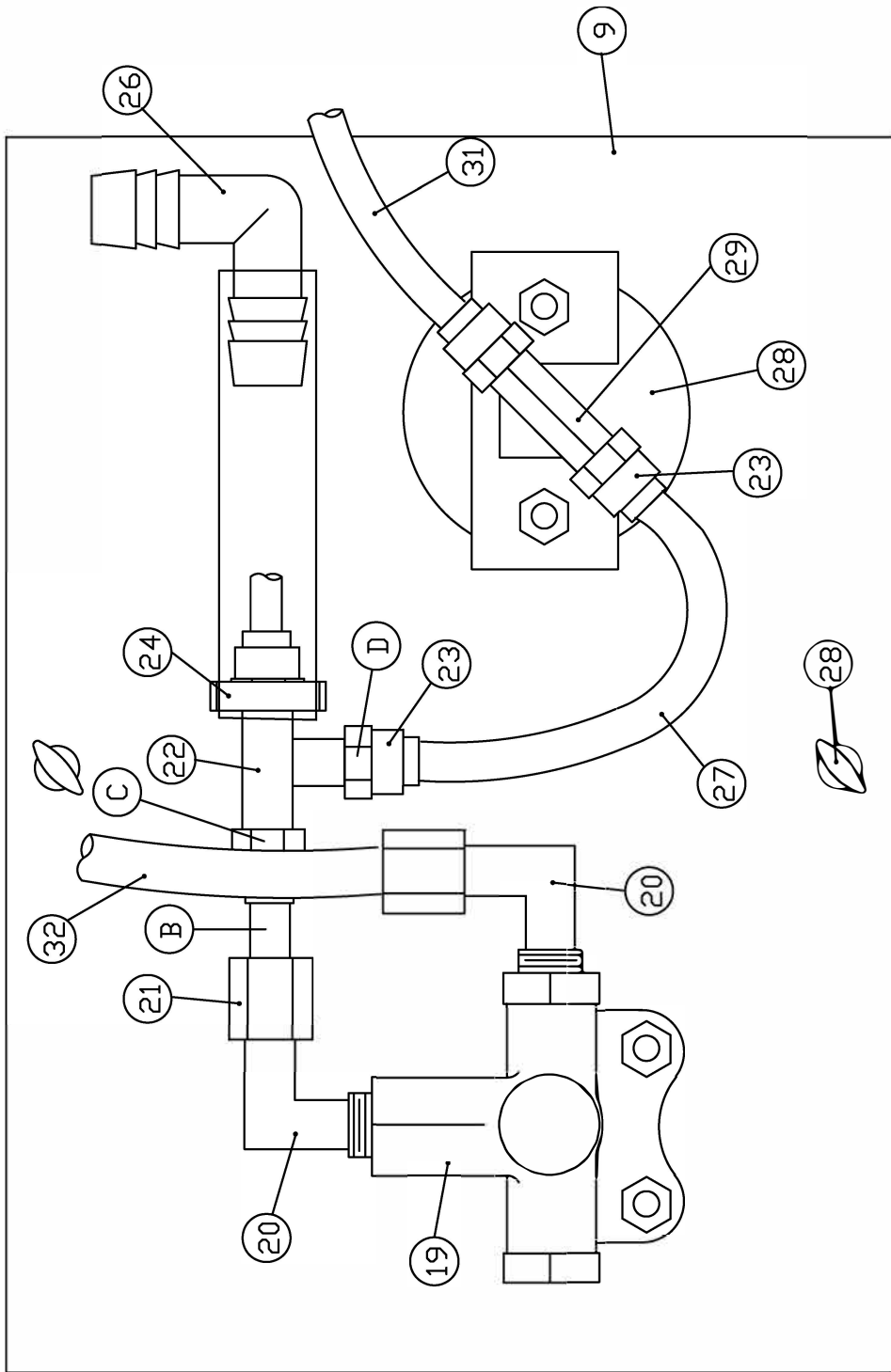

| | | | | |
|--|---------------------------------------|----------------|--------------|----------|
| THIS DRAWING IS THE EXCLUSIVE AND CONFIDENTIAL PROPERTY OF GETZ MFG. IT SHALL NOT BE DUPLICATED, USED OR DISCLOSED TO OTHERS WITHOUT THE EXPRESS WRITTEN CONSENT OF GETZ EQUIPMENT | | BIN NO. | | 4 □ F 5 |
| A CHANGED PART 26 | | REV. | | 58836-4M |
| REV | DRAWING CHANGE | BY | ECN NO. | DWG. NO. |
| | TOLERANCES UNLESS OTHERWISE SPECIFIED | | | |
| FRAC. ±.020 | 2 PL DEC ±.010 | 3 PL DEC ±.003 | | |
| 12/2 | MATERIAL | FINISH | TITLE | |
| 05 | | OK'D | SGL SV 50 PR | |
| DATE | DWN BY | K.L.R. | | |
| | R.D.M. | DATE | | |
| | SCALE | 7-29-04 | | |
| | 1"=1" | | | |



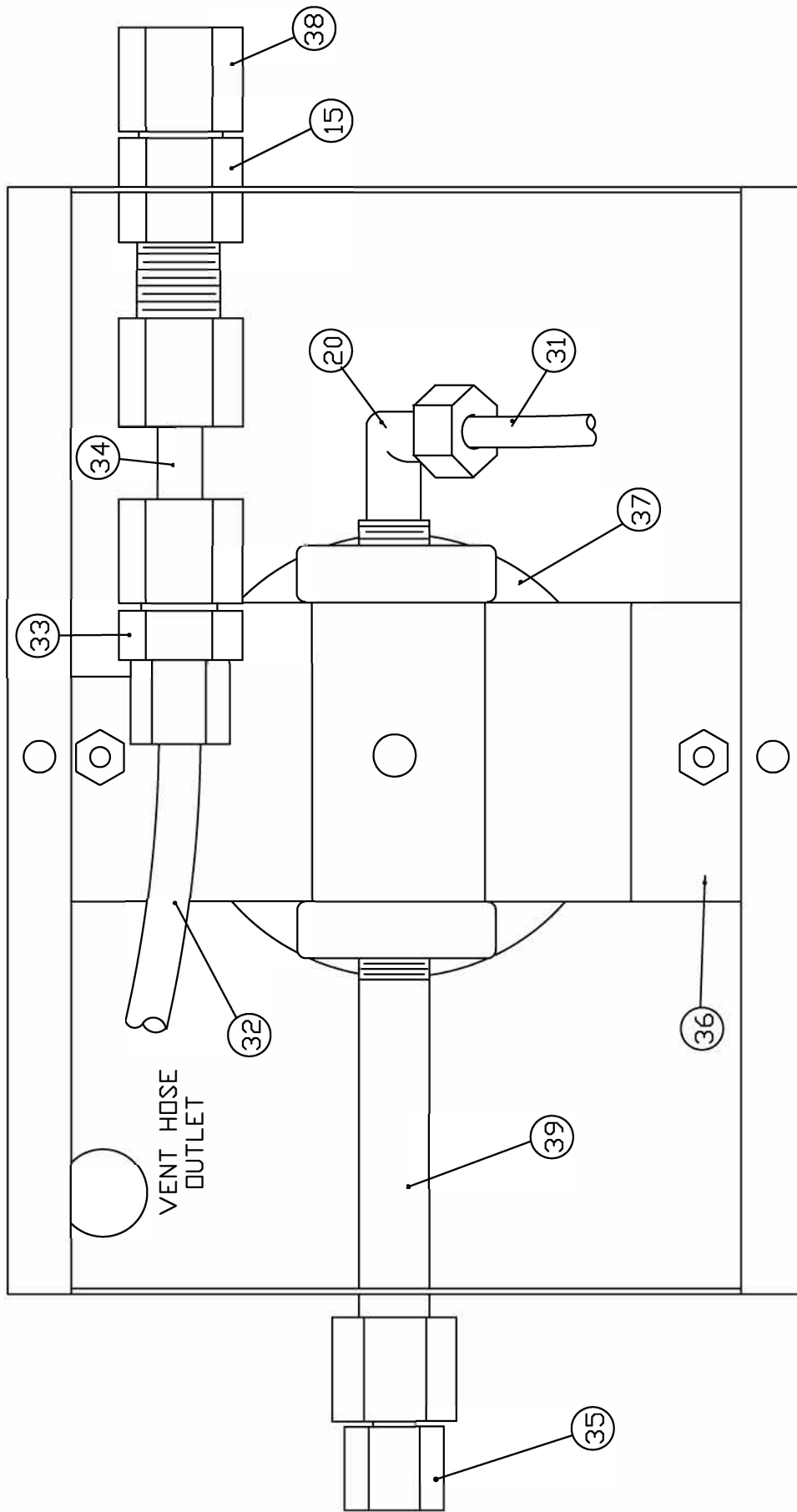

FRONT OF CONSOLE BODY

THIS DRAWING IS THE EXCLUSIVE AND CONFIDENTIAL PROPERTY OF GETZ MFG. IT SHALL NOT BE DUPLICATED, USED OR DISCLOSED TO OTHERS WITHOUT THE EXPRESS WRITTEN CONSENT OF GETZ EQUIPMENT

| | | | | | | | | | | |
|---------------------------------------|----------------|--------|---------|------|-----------------------|--|-----------|--|----------|--|
| DRAWING CHANGE | | BY | ECN NO. | DATE | FINISH | | SHEET NO. | | BIN NO. | |
| TOLERANCES UNLESS OTHERWISE SPECIFIED | | R.D.M. | | | OK'D K.L.R. | | 5 OF 5 | | 58836-5M | |
| FRAC. ±.020 | 2 PL DEC ±.010 | | | | DATE 7-29-04 | | DWG. NO. | | REV. | |
| | 3 PL DEC ±.003 | | | | TITLE SGL SV 50 PR | | 58836-5M | | * | |



ASSEMBLY INSTRUCTIONS

1. Assembly unit per drawing #1 of 4 enclosed.
 - A) Install SV1 console (#8) slide the console clips on the bracket (#2), snapping the bolt heads into the holes of the bracket.
 - B) Install ring bracket (#54) into the two holes provided on the front left side of hopper and stand.
** (Bolts and nuts are located in a package in the hopper.)
 - C) Install the discharge assembly (#3) into the front top center $\frac{3}{4}$ " port, meyer hub (#42), provided on the front of hopper.
 - D) Assemble hoses to console matching numbers on hoses to numbers at fitting on console.
 - E) Assemble $\frac{1}{2}$ " clear hose (#6) to the 45 degree hopper outlet on bottom of hopper.

Note: You will find it much easier to get the hose on the bottom of hopper if you preheat the end of the hose in a cup of very hot water.
 - F) Attach the 6' piece of $\frac{1}{2}$ " tubing to the vent hose connection which is the black plastic nipple on the bottom of the console this is an air vent line.
 - G) Attach connector (#17) from right hand side of the console to your regulated air supply.
(Approximately 70 PSI.)
2. Adjust regulator for approximately 60 to 90 PSI and turn air pressure on. (See page 1 for proper regulator setting.) To operate unit, place appropriate cone in neck of fire extinguisher. Turn appropriate valve to "ON" position. This will create vacuum in the extinguisher causing it to fill with chemical to proper weight predetermined by scale. If chemical flows into jar below console, cylinder has become full. At this time you must allow it to settle in cylinder if proper weight has not been reached tapping cylinder with a rubber hammer will speed up the setting of chemical.

PORTABLE EXTINGUISHER DISCHARGE INSTRUCTIONS

1. Make sure the portable extinguisher is pressurized.
2. If portable extinguisher is not pressurized, and is full or partially full of chemical, discharge the contents of the extinguisher into the hopper system and pour out of vacuum the remaining chemical for the extinguisher.
3. Connect proper discharge adapter with male quick coupler into valve assembly of extinguisher.
4. Connect discharge assembly (#3) to your discharge adapter on extinguisher.
5. make sure the powder recovery lid is properly clamped to hopper.
6. Close valve (#45) and partially discharge extinguisher in the discharge hose (#47) to inspect chemical.
7. If chemical appears to be ok, you may open valve (#45) which will let the chemical enter the hopper and allow nitrogen pressure to escape through the powder recovery filter.
8. After pressure gauge is to zero, you may disconnect the discharge assembly hose and proceed to inspect or hydrotest the extinguisher.
9. Remove valve from extinguisher and cleaning:
 - A. Clean all powder out of thread of neck of extinguisher. (Use a toothbrush).
 - B. Clean interior of valve assembly and valve stem. (This is very important to make sure extinguisher does not leak off).
 - C. Clean threads of valve assembly and clean and lubricate O-ring.
 - D. Return valve and siphon tube assembly into neck on extinguisher. (Hand tighten)
 - E. Select the correct pressurizing adapter and place into discharge port.
 - F. Set regulator. Squeeze level and pressurize to working pressure reading on gauge.
 - G. Once reaching proper pressure reading on gauge, release lever.
 - H. Disconnect recharge adapter and replace pull-pin for safety.
 - I. Check for leaks around neck O-ring and discharge port.
 - J. Follow up with returning hose assembly and tag to extinguisher.

FILLING EMPTY DRY CHEMICAL EXTINGUISHERS

1. Make sure scale is perfectly set and balanced to zero.
2. Make sure empty dry chemical extinguisher is visually checked on the inside for dryness and corrosion with inspection light.
3. Check label on empty extinguisher for type of chemical to be filled with.
4. The filling lines are also colored yellow and white, so you know yellow is ABC and white is BC chemical.
5. Set empty extinguisher on scale and check proper weight to be filled on extinguisher label.
6. Once proper chemical is determined, take yellow or white filling line and extend it to the top of the empty cylinder to be filled.
7. Take the rubber cone on the end of the filling line and place into top of cylinder neck with a 1/4 turn clockwise.
8. Scale: Two ways of weighting extinguisher for proper filling:
 - A. With extinguisher and filling line attached on scale, return scale back to zero and proceed to fill to recommended weight.
 - B. With extinguisher and filling line attached on scale, you can add recommended weight to the weight reading of extinguisher and fill line presently on scale.
9. Turn on-off valve to the "ON" position until extinguisher reaches recommended weight. Then turn valve to "OFF" position once extinguisher is filled. (if chemical returns to plastic jar before reaching proper weight, let chemical settle then turn valve back to "ON" to get recommended weight.)
10. Remove filling line from neck of extinguisher to filling line ring bracket.

TROUBLE SHOOTING AND SERVICE AIDS

1. Chemical will not flow when:
 - A. Extinguisher is not vacuum tight. (i.e., a cartridge extinguisher with a leaky cartridge receiver.)
 - B. There must be a kink in hose.
 - C. The filling line and/or vacuum line may be clogged.

NOTE: NEVER BLOW AIR PRESSURE INTO THE VACU-FILL CONSOLE OR JAR ASSEMBLY. MAY CAUSE INJURY OR DAMAGE TO THE CONSOLE.
 - D. Jar filter assembly on console is not properly sealed.
(Jar must be screwed on tight.)
 - E. Air supply is not regulated and maintained at 60 to 90 PSI.
2. Filter jars located under console should never be allowed to fill more than half way before emptying.
 - A. Filter element in jars may be blown clean with an air gun or similar device weekly. Replace filter twice a year.
3. The on/off valve on the console may, after a period of time, tend to tighten up or become harder to operate.
 - A. First thing shut off air pressure to console and bleed out all pressure in the system.
 - B. To dismantle valve (#19), simply loosen the nut or cap around the stem, (counter-clockwise) and using the handle, turn to "ON" position and pull entire stem, nut and bushing out of the valve body. Note the position of the key just behind the spring so you can reassemble valve correctly.

Using carburetor cleaner or similar cleaner, clean inner valve body and the bushing with two holes in it.

Put a thin film of lubriplate, or similar lubricant, on both parts.

Pull the small inner O-ring and the spring towards the handle and reassemble valve, mating key washer in the valve slot. (The small O-ring seals and prevents leaks around stem.)

TROUBLE SHOOTING AND SERVICE AIDS

(CONTINUED)

To determine if the problem is in the console, remove vacuum line (#5) from connector (#35) located on lower left side of console.

Now, with the vacuum line (#5) removed from the outside of console, place your finger over the fitting, (#35), on the outside of the console and turn on the valve. You should feel suction here, and the gauge should read over 15" of vacuum. If not, make sure jar gasket in (#37) is in place and make sure the jar is tight against gasket.

DO NOT BLOW AIR THROUGH CONSOLE OR JAR ASSEMBLY

JAR IS LIKELY TO EXPLODE IF SUBJECT TO MORE THAN 5 PSI

If you have suction at fitting (35), you can be assured that the trouble is not in the console.

Most common problems outside the console are: lumpy chemical, moist chemical, and a plugged filling hose.

** If the console is not working properly, we recommend replacing the venturi, (#22).

PROCEDURE FOR CHANGING VENTURI VALVES ON VACU-FILL SYSTEM

1. Turn the two cover-locking screws a half turn and remove the cover so that the inside of the Console is exposed.
2. Using a 7/16" open end wrench, remove the nut (C) for the venturi.
3. Pull out plastic hose end (B).
4. Remove nut (D) and put out the end of the plastic hose (#27).
5. Remove the old venturi (#22) by unscrewing it from the crimped clamp (#24).
6. Place the end of the new venturi into the crimped clamp (#24).
7. Replace hose end (#27), and tighten nut (D).
8. Replace hose end (B), and tighten nut (C).
9. Replace cover and tighten cover-locking screws.

RECOMMENDED MAINTENANCE KIT

Dear Customer:

Your recent purchase of our vacu-fill system will provide you with many years of dependable service.

Rest assured you have purchased the finest system available in today's marketplace. The advanced engineering and technological advancement employed in the development of this quality product has made it without equal, worldwide.

While this system is perhaps the most maintenance-free of any we manufacture, it must be remembered that anything man-made is capable of malfunctioning and may require simple repair.

For this reason, we have put together a maintenance kit which will eliminate the need for delay should your system ever fail. Chances are it won't. Yet, on occasion problems do arise for one reason or another. Call it an extra ounce of security.

I urge your consideration and modest investment in the following. Should you ever experience a problem, chances are you'll be equipped to repair it on the spot

1 - 3G58901 - KIT SERV & MAINT SV 50 PR

Sincerely,

Getz Equipment

Note:

Do not modify any components within this system. Any use of parts other than Getz Equipment components excludes all written and implied liabilities.