



A DIVISION OF GETZ FIRE EQUIPMENT

Getz Equipment Innovators
Vacufill Systems Instruction
Manual
3G58605 – 3G58608 – 3G58610
3G59109 – 3G59218 – 3G59230



2320 Lakecrest Drive, Pekin IL 61554
PH. (888) 747-4389 • Fax (309) 495-0625
Website: www.getzequipment.com

LIMITED WARRANTY

Getz Equipment Innovators warrants its products, and component parts of any product manufactured by Getz Equipment Innovators, to be free from defects in material and workmanship for a period of twelve (12) months from the date of purchase. During the warranty period, any such defects will be repaired or the defective parts replaced **(at Getz Equipment Innovators' option)**. The warranty does not cover defects resulting from modification, alteration, misuse, exposure to corrosive conditions, extremely high temperatures, improper installation or maintenance. Warranties on component items not manufactured by Getz Equipment Innovators are provided by others whose warranty, evaluation and judgment will be final.

All implied warranties, including, but not limited to, warranties of fitness for purpose and merchantability, are limited to the time periods as stated above. In no event shall Getz Equipment Innovators be liable to incidental or consequential damages. Some states do not allow limitations on how long an implied warranty lasts or the exclusions or limitation of incidental or consequential damages, so that the above limitations or exclusions may not apply to you. Getz Equipment Innovators neither assumes nor authorizes any representative or other person to assume for it any obligation or liability other than as expressly set forth herein.

Mobile Service Vehicles:

The warranty does not cover:

- Defects in the chassis and or power unit
- Defects in separately manufactured products not produced by Getz Equipment Innovators
- Deterioration due to normal wear, tear, and exposure
- Repairs made necessary by negligent use, misuse, abuse, loading the service vehicle beyond its gross vehicle weight limitations, accident, acts of God, or other contingencies beyond the control of Getz Equipment Innovators.
- Repairs deemed necessary by reason of the failure to follow ordinary maintenance procedures.
- Repairs deemed necessary by reason of alterations done without Getz Equipment Innovators' written approval.

Warranty Service:

- All warranty repairs will be performed by Getz Equipment Innovators in Pekin, IL, unless otherwise authorized by Getz Equipment Innovators.

Freight:

- Getz Equipment Innovators will not be liable for shipping or transportation charges to or from customer's location.

This warranty gives you specific legal rights, and you may also have other rights which vary from state to state. To obtain performance to the obligation of the warranty, write to Getz Equipment Innovators, 2320 Lakecrest Drive, Pekin IL 61554, USA for instructions.

!!WARNING!!

SEVERE DAMAGE AND/OR INJURY MAY RESULT

50 & 100 # CAPACITY VACUFILLS:

**DO NOT DISCHARGE ANY EXTINGUISHER
CYLINDER EXCEEDING 195 PSI AND NOT
EXCEEDING 30 POUNDS IN AGENT WEIGHT.**

150 # CAPACITY VACUFILLS:

**DO NOT DISCHARGE ANY EXTINGUISHER
CYLINDER EXCEEDING 195 PSI WITHOUT THE
USE OF GETZ EQUIPMENT P/N 3G59745,
WHEELED SYSTEM DISCHARGE ASSEMBLY,
INSTALLED.**

**FAILURE TO INSTALL AND OPERATE
EQUIPMENT ACCORDING TO THE
GUIDELINES PUT FORTH IN THE
INSTRUCTION MANUAL SHALL VOID
WARRANTY.**

Getz VacuFill Systems

Table of Contents

1	Introduction & Operation Requirements
2-4	Assembly Instructions
5-6	Parts List
7	3G58608 – V1 Vacu-full system Drawing
8	3G58540-1M – V1 VacuFill Console Box Drawing
9	3G58540-2M – V1 Vacu-Fill Console Lid Drawing
10	3G58605 – V2 VacuFill System Drawing
11	3G58541-1M – V2 VacuFill Console Box Drawing
12	3G58541-2M – V2 VacuFill Console Lid Drawing
13	3G58610 – V3 VacuFill System Drawing
14	3G58542 -1M – V3 VacuFill Console Box Drawing
15	3G58542-2M – V3 VacuFill Console Lid Drawing
16	3G58542-M – Discharge Assembly Drawing
17-18	Operating Instructions
19	Maintenance Schedule
20-21	Trouble Shooting Guide
22	Checking Vacuum Reading
23	Procedure for Changing Venturi
24	Replacement Parts
25	Recommended Maintenance Kit

Introduction & Operating Requirements

This manual describes the operation of the Getz models V1-V2-V3 150 PR VacuFill systems. The principles of operation and maintenance are the same with each model. The only difference is in the control console and number of hoppers.

Operation Cautions and Warnings

- Read instructions manual thoroughly
- Operation must wear safety glasses when operation this equipment
- Do not modify any components within the system, any use other than Getz Equipment components exclude all written and implied liabilities
- Do not use glass jars in place of plastic jars on console
- Any use of glass jars will exclude all written and implied liabilities

System Requirements for Operations

1. Operation must supply one source of the following to power VacuFill system:

Compressed air cylinder w/ regulator	Consumption rate
Nitrogen cylinder w/ regulator	2 CFM at 50 to 65 PSI
Air compressor w/ regulator & moisture filter	or approximately
CO2 vapor cylinder w/ regulator	2 bar to 5.5 bar

Note – siphon tube must be removed from supply valve of liquid CO2 cylinder

High pressure cylinder regulator – Getz part #3G0012
Low pressure air compressor regulator – Getz part #3G0011

2. Discharge/recharge adapters:
Getz part #3G0009 – Set of 10 adapters with male quick connect.
3. Nitrogen cylinder with regulator & nitrogen recharge line pre-pressurizing the extinguisher:
Regulator – Getz part #3G0132
Nitrogen recharge line – Getz part #3G0022
4. Weighing scale:
Digital – Getz part #2G0043 0-110 LBS. capacity
Legal for Trade - Getz part#2G0131 0-150 LBS. capacity

Chemical capacity of hopper or hoppers – 150 LBS. or 68 KG per hopper.

Shipping dimensions & weight of VacuFill systems & components:

Model #V1-150-PR	31 X 18 X 40 in. – 80 LBS. – (36 KG)
Model #V2-150-PR	31 X 18 X 40 in. – 95 LBS. – (43 KG)
3 rd Hopper & frame	17 X 18 X 40 in. – 55 LBS. – (25 KG)
Vacu-fill Console	18 X 14 X 11 in – 25 LBS. – (11 KG)
Console Arch	7 X 5 X 48 in. – 15 LBS. – (7 KG)
Scale frame	16 X 17 X 17 in. – 12 LS. – (5.5 KG)

Assembly instructions

Assemble the VacuFill system per drawing V1, V2, or V3
Depending on the model purchased

1. Unpack all the cardboard shipping boxes that contain the VacuFill system.
2. Place the double hopper stand, with the hopper or hoppers already installed in the stand, in the area you have selected. If the V3 VacuFill system was purchased, you will need to bolt the 3rd hopper stand onto the right hand side of the double hopper stand with the bolts provided in the 3rd hopper stand box. Place the alternate hopper in this stand.

Optional – Scale Stand – Part# 1G51322

Place the scale stand on left hand side of double hopper stand and bolt it to the double hopper stand with the bolts provided in the scale stand box.

Optional – Console Arch – Part #1G51319

Insert the two console arch side brackets into the two open holes in back of the top of the double hopper stand. Place the two open holes on the bottom of the console arch bracket onto the side console arch brackets. Tap the top of the console arch bracket with a rubber hammer to secure the console arch to the double hopper frame.

3. Locate the discharge assembly or assemblies by looking at page #16. Screw (#62) that is assembled on the discharge assembly, into (#50), which is already installed on the hopper or hoppers. Refer to the VacuFill system drawing of the model that was purchased in the manual.

Note – If part #1G51319 (console arch) was purchased, go to step 5.

4. Place the assembled hopper system up against a wall, and then place the control console box (#43) above the top of the hopper system. Center the console box between the double hopper stand and locate the top of the console box at 58" from the floor by following the drawing of the model purchased. Arc a pencil line on the wall around the console box, then remove the console box from the wall. Place a flat blade screwdriver in the two cover locking screws located in the middle of the right and left side of the console box's front cover. Turn the locking screws ½ turn to the right or left to release the front cover from the console box. Lift the front cover away from the console box to expose the four (4) mounting holes in the back of the console box. Relocate the console box to the penciled outline on the wall and secure the console box with four (4) screws or bolts. Replace the front cover on the console box carefully, making sure the plastic tubing inside the console box does not kink or bend. Place a flat blade screwdriver back into the cover locking screws and turn ½ turn to the right or left, locking the front cover back onto the console box.

5. Place the control console box (#43) flat on the side opposite the on-off valves. One at a time, place a flat blade screwdriver in the two cover locking screws located in the middle of the right and left side of the console box's front cover. Turn the locking screws ½ turn to the right or left to release the front cover from the console box. Lift the front cover away from the console box to expose the four (4) mounting holes in the back of the console box. Mount the console box to the four (4) holes in the middle of the console arch with the four (4) bolts that come with the console arch. Replace the front cover on the console box does not kink or bend. Place a flat blade screwdriver back into the cover locking screws and turn ½ turn to the right or left, locking the front cover back on the console box.
6. Located on the bottom of the console box (#43), are either one, two, or three ½" barbed nipples (#41, #72 or #42), depending on the model of VacuFill system that was purchased. Connect the 6' clear ½" vent line or lines (#3, #74, or #75) to the barbed nipple by pushing the plastic tubing over the barbed nipple. Either vent this to outside air or allow the vent line or lines to lay behind the hopper system.

Note – The vent line or lines must be free of kinks or restriction in order for maximum vacuum to be achieved when filling extinguishers.

Note – If part #1G51319 – console arch was purchased go to step #8.

7. Locate ring bracket or bracket (#45) that came packed with the console box (#43). Using the top of the console box as a center line guide, place the first ring bracket on the wall 9" from the left side of the console box. Center the ring brackets round ring level with the top of the console box and secure the ring bracket to the wall with screws or bolts. Place any additional ring brackets 5" apart from the center of the first ring bracket. Keep the ring bracket level with the top of the console box.
8. Locate the ABC fill line (#8) which has the yellow ¼" plastic tubing connected to the clear ½" plastic fill line. Slip the yellow plastic tubing and the clear plastic tubing ends that are at the opposite end of the black fill cone (#44) through the ring bracket farthest from the console box, as shown on the drawing of the model purchased. The ¼" yellow tubing has a (#7) on it and will correspond the (#7) on the console box's connector port, located on the lower left side of the console box. Loosen the plastic nut on port (#7) of the console box and slip the ¼" yellow line into the connector until it stops. Tighten the plastic nut securely with your fingers. Route the ½" clear fill line (#8) through the left end of the double hopper stand (#55) and place the fill line at the cone on the bottom of the ABC hopper as shown in the drawing. Heat some water up to boiling point and stick 2" of the end of the fill line into the water until the end of the fill line is soft and pliable. Slip the white plastic clamp provided with the fill line over the fill line and with the aid of a small screwdriver, work the fill onto the cone on the bottom of the ABC hopper. Slide the white plastic clamp to within ¼" of the end of the fill line and secure the clamp by squeezing the clamp top ears together with your fingers.

9. The BC fill line (#6) will have a ¼” clear plastic line attached to the ½” clear fill line and will have a (#5) on it which will connect to port (#5) on the console box, located on the lower right side. The ½” clear fill line (#6) will connect to the BC hopper as the drawing shows and will go into the next ring bracket working towards the console box.
10. The alternate fill line (#10) will have a ¼” blue plastic line attached to the ½” clear fill line and will have a (#9) on it which connects to port (#9) on the console box, located on the upper left side. The ½” clear fill line (#10) will connect to the alternate hopper as the drawing shows and will go into the next ring bracket working toward the console box.
11. Locate the 3/8” plastic clear tubing with the (#4) on it, and place the end of the plastic tubing without the connection on it into the (#4) port of the console box by loosening the plastic nut on the connector at the (#4) port and slip the plastic tubing on the plastic nut until it stops. Secure the plastic tubing by tightening the plastic nut securely with your fingers. Remove the connector on the other end of line (#4) by unscrewing the plastic nut away from the connector body. Take the connector body end with the ¼” NPT threads and place thread tape or pipe sealant on the threads. Set the incoming air supply regulator to “0” output pressure and screw the ¼” NPT threaded connector body into the regulator's outlet port. Place the plastic nut that is on line (#4) onto the plastic connector body that is in the regulator outlet port and secure line (#4) to the regulator by screwing the plastic nut down securely with your fingers.
12. Turn the on-off valves, located on the front of the console box (#43) to the “OFF” position. Increase the incoming supply pressure to the console to 60 PSI or 4 bars by adjusting your incoming supply regulator that is connected to line (#4) on the console box.
13. Place your weighting scale on the left hand side of the VacuFill system, either on the “optional scale stand” part #1G51322 or an appropriate platform.
14. Set your scale to read “0” on the dial or indicator and place a test weight on the scale to verify accuracy.

VacuFill Parts List

<u>Drawing #</u>	<u>Part #</u>	<u>Part Description</u>
1	1G51474	LID CONSOLE V123
2	3G58645	VLV ON-OF BR BC
3	1G0032	MTL VINYL TUBE ½ CLR X 6'
4	1G0041	CLAMP OETIKER ¾
5	1G0048	MTL NYCOIL ¼ WH X 7'
6	1G0032	MTL VINYL TUBE ½ CLR X 9'
7	1G0047	MTL NYCOIL ¼ YL X 6'
8	1G0032	MTL VINYL TUBE ½ CLR X 9'
9	1G51550	MTL NYCOIL ¼ BL X 7'
10	1G0032	MTL VINYL TUBE ½ CLR X 9'
11	1G0021	VENTURI COMPLETE
12	1G0041	CLAMP OETIKER ¾
13	1G0046	MTL NYCOIL ¼ RD X 13"
14	1G0032	MTL VINYL TUBE ½ CLR X 4"
15	1G51550	MTL NYCOIL ¼ BL X 6 ½"
16	1G0046	MTL NYCOIL ¼ RD X 11"
17	1G0032	MTL VINYL TUBE ½ CLR X 7 ½"
18	1G0047	MTL NYCOIL ¼ YL X 11"
19	BRKT	GAUGE BRACKET
20	1G0200	PIPE TEE ¼ X 1/8 FMLE BRANCH
21	1G0018	GAUGE 30MG VACUUM
22	1G0047	MTL NYCOIL ¼ YL X 11"
23	1G51550	MTL NYCOIL ¼ BL X 11"
24	1G0048	MTL NYCOIL ¼ WH X 11"
25	1G0099	PIPE ELB PLAS ½ W/BARB
26	1G51709	PIPE UNION PLAS 3/8 WH X 3"
27	1G58651	VLV ON-OFF BR ABC
28	1G0049	MTL NYCOIL 3/8 WH X 3'
29	1G51710	PIPE UNION RDCR PLAS 3/8 X ¼
30	1G0032	MTL VINYL TUBE ½ CLR X 5 ½"
31	1G51550	MTL NYCOIL ¼ BL X 12 ½"
32		
33	1G0136	CONNECTOR PLAS ¼ ML X ¼ TUBE
34	1G0017	FLTR ASY CASTING W/O JAR
35	1G0011	BKT FLTR ASY JAR CLP
36	1G0205	GASKET JAR
37	1G0067	FLTR WH JAR ASSY
38	1G0206	CAP FILTER
39	1G51436	JAR PLASTIC (DO NOT USE GLASS JARS)
40	1G58644	VLV ON-OFF BR MIDDLE
41	1G56314	BULKHEAD ASY ½ BARB
42	1G56314	BULKHEAD ASY ½ BARB
43	1G51149	BOX CONSOLE V123

VacuFill Parts List (Continued)

<u>Drawing #</u>	<u>Part #</u>	<u>Part Description</u>
44	1G51221	CONE FILL
45	1G0014	BKT RING
46	1G58561	FTNG BR FILLER TUBE COMP
47	1G51319	FRAME CONSOLE
48	1G51404	HOPPER 150# ONLY
49	1G51469	LATCH HOPPER
50	1G51428	HUB MEYER ¾ FMLE X FMLE
51	1G58545	DCH ASY (SEE "DETAIL A" ON PAGE 16)
52	1G58577	LID PWDR RECO YL (SPECIFY COLOR OF LID)
53	1G54040	FLTR FOR HOPPER LID
54	1G51322	FRAME SCALE
55	1G51833	STAND HOPPER DOUBLE
56	1G0046	MTL NYCOIL ¼ RD X 10"
57	1G51627	CASTING ELB BR 45 DEG HOPPER
58	1G51322	FRAME 3 RD HOPPER
59	1G51302	FASTENER LOCKING CONSOLE
60	1G0046	MTL NYCOIL 1.4 RD X 1 ½"
61	1G51703	PIPE TEE PLAS ¼ ML
62	1G51686	PIPE RDCE BR ¾ X ½
63	1G0077	PIPE ELB BR ½ X ½ ML
64	1G51895	VLV BALL ½
65	1G0075	BARB HOSE BR ½ X ½
66	1G0041	CLAMP OETIKER ¾
67	1G0033	MTL NYLON TUBE DCA1 5/8 X 3'
68	1G0076	BARB HOSE BR ½ X ¼
69	1G0028	CPLG ¼ FMLE STR THRU
70	1G0025	CPLG ¼ X 1/8 ML STR
71	1G51789	SCREEN DCH
72	1G0207	STEM FILTER
73	51663	PIPE NIP PLAS ½ BARBED
74	1G0032	MTL VINYL TUBE ½ CLR X 6'
75	1G0032	MTL VINYL TUBE ½ CLR X 6'
76		
77	1G0032	MTL VINYL TUBE ½ CLR X 6'
78	1G51798	SEAL Q/CONNECT NEOPRENE
79	1G0046	MTL NYCOIL ¼ RD X 4 ½"
80	1G0120	PIPE ELB PLAS ¼ ML X ¼ TUBE
81	1G51688	PIPE TEE ¼ ML BRANCH
82	1G0048	MTL NYCOIL ¼ WH X 5 ½"
83	1G58540	CONSOLE V1 COMPLETE
84	1G58541	CONSOLE V2 COMPLETE
85	1G58542	CONSOLE V3 COMPLETE

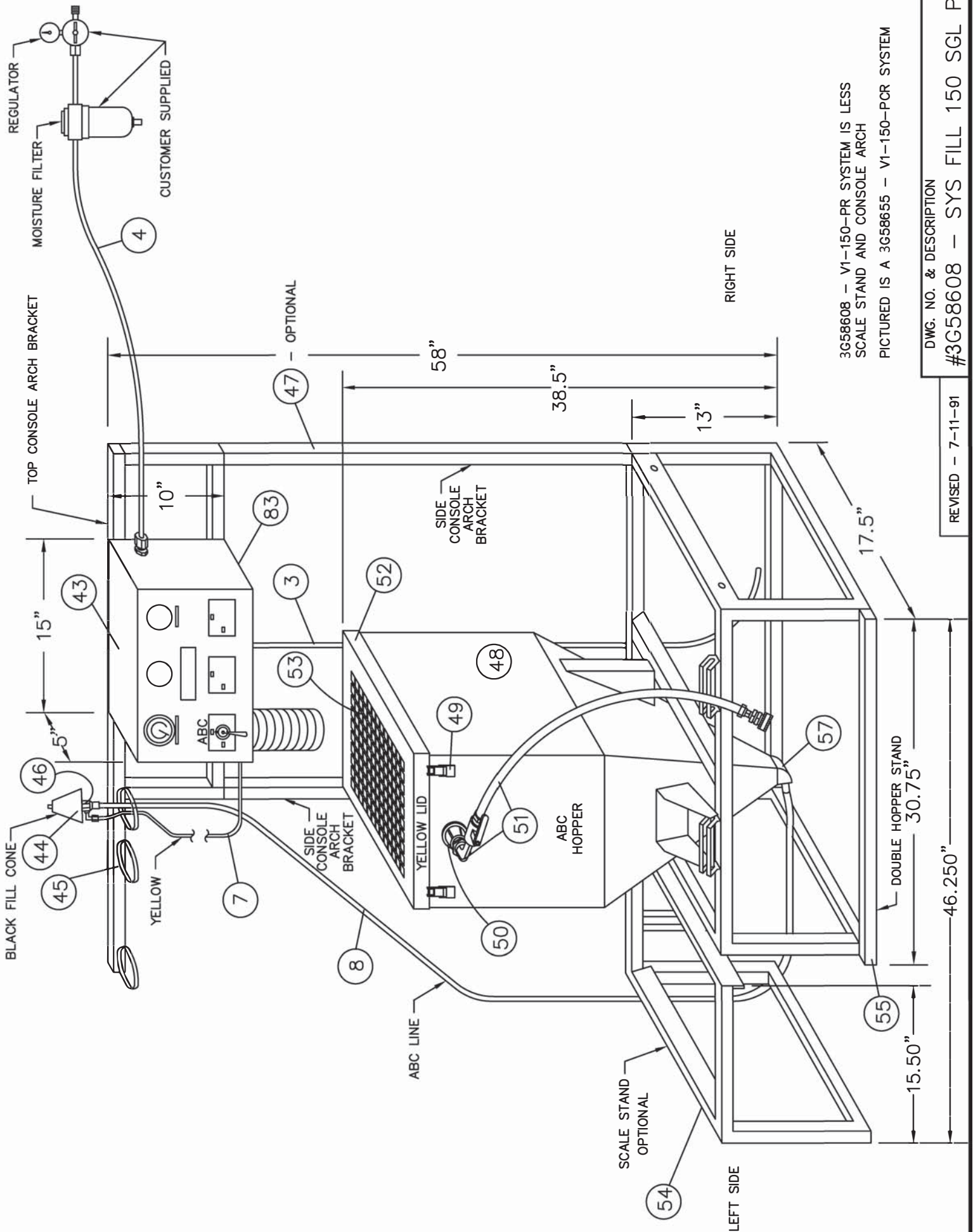

3G58608 - V1-150-PR SYSTEM IS LESS
 SCALE STAND AND CONSOLE ARCH
 PICTURED IS A 3G58655 - V1-150-PCR SYSTEM

DWG. NO. & DESCRIPTION

#3G58608 - SYS FILL 150 SGL PR

REVISED - 7-11-91

TOP OF CONSOLE BOX

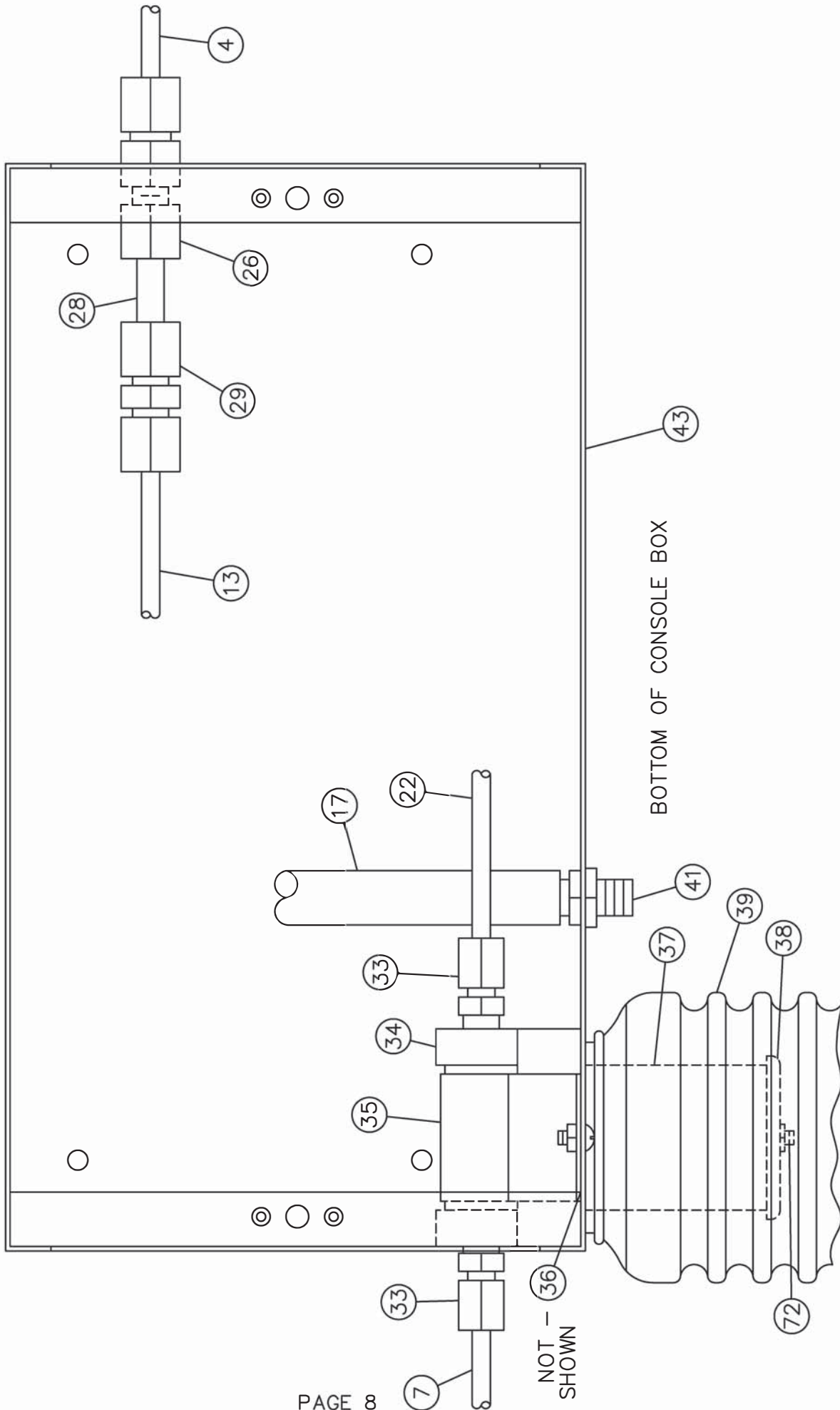

THIS DRAWING IS THE EXCLUSIVE AND CONFIDENTIAL PROPERTY OF GETZ EQ. IT SHALL NOT BE DUPLICATED, USED OR DISCLOSED TO OTHERS WITHOUT THE EXPRESS WRITTEN CONSENT OF GETZ EQUIPMENT

REV	DRAWING CHANGE	BY	ECN NO.	DATE	MATERIAL	FINISH	BIN NO.
					DWN BY U.A.L.	K.P.R.	1 OF 1
TOLERANCES UNLESS OTHERWISE SPECIFIED					SCALE 1/2" = 1"	DATE 7-1-91	DWG. NO.
FRAC. ±.020	2 PL DEC ±.010	3 PL DEC ±.003			TITLE V-1 VACU-FILL BOX INTERIOR		REV. 3G58540-1M *

GETZ EQUIPMENT INNOVATORS

PEKIN, ILLINOIS

V-1 VACU-FILL BOX INTERIOR

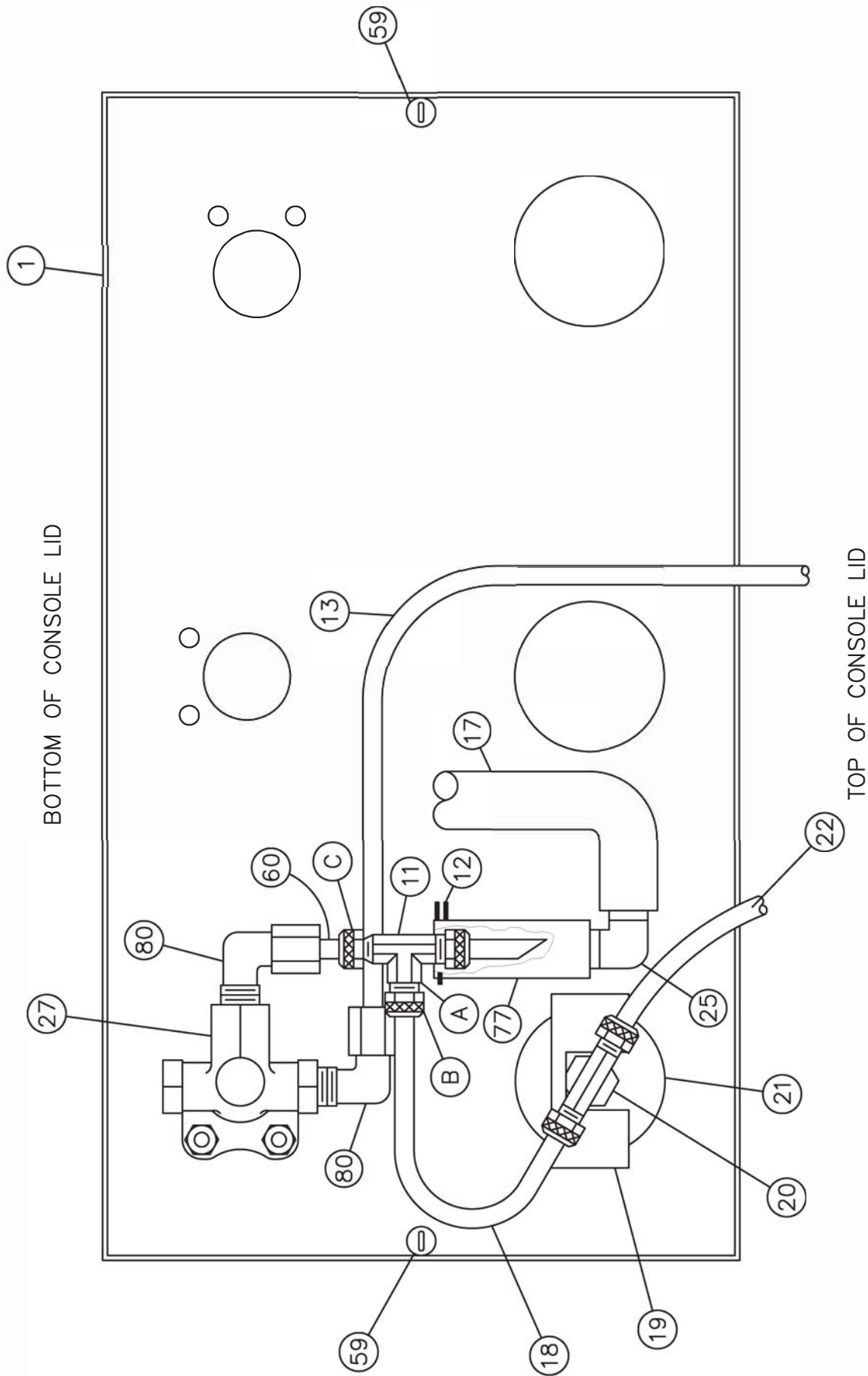

BOTTOM OF CONSOLE LID

TOP OF CONSOLE LID

THIS DRAWING IS THE EXCLUSIVE AND CONFIDENTIAL PROPERTY OF GETZ EQ. IT SHALL NOT BE DUPLICATED, USED OR DISCLOSED TO OTHERS WITHOUT THE EXPRESS WRITTEN CONSENT OF GETZ EQUIPMENT.

REV	DRAWING CHANGE	BY	ECN NO.	DATE	MATERIAL	FINISH	SHEET NO.	BIN NO.
					DWN BY U.A.L.	K.P.R.	1 OF 1	
TOLERANCES UNLESS OTHERWISE SPECIFIED							DWG. NO.	REV.
							3G58540-2M	*
FRAC. ±.020	2 PL DEC ±.010	3 PL DEC ±.003	TITLE				V-1 CONSOLE LID INTERIOR	
							GETZ EQUIPMENT INNOVATORS PEKIN, ILLINOIS	

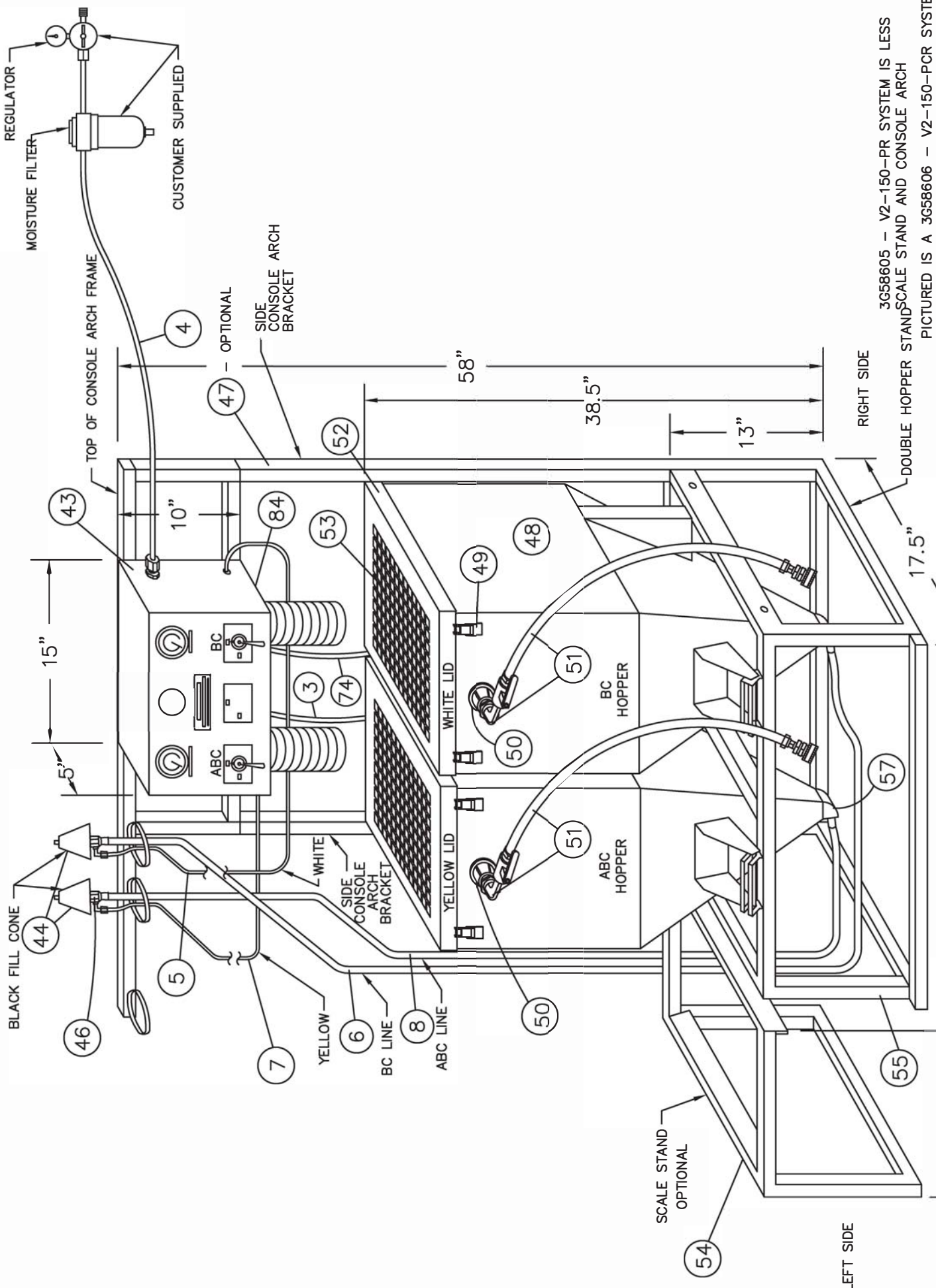

3G58605 - V2-150-PR SYSTEM IS LESS
 SCALE STAND AND CONSOLE ARCH
 PICTURED IS A 3G58606 - V2-150-PCR SYSTEM

DWG. NO. & DESCRIPTION
 3G58605 - SYS FILL 150 DUAL PR

REVISED - 2-22-93

TOP OF CONSOLE BOX

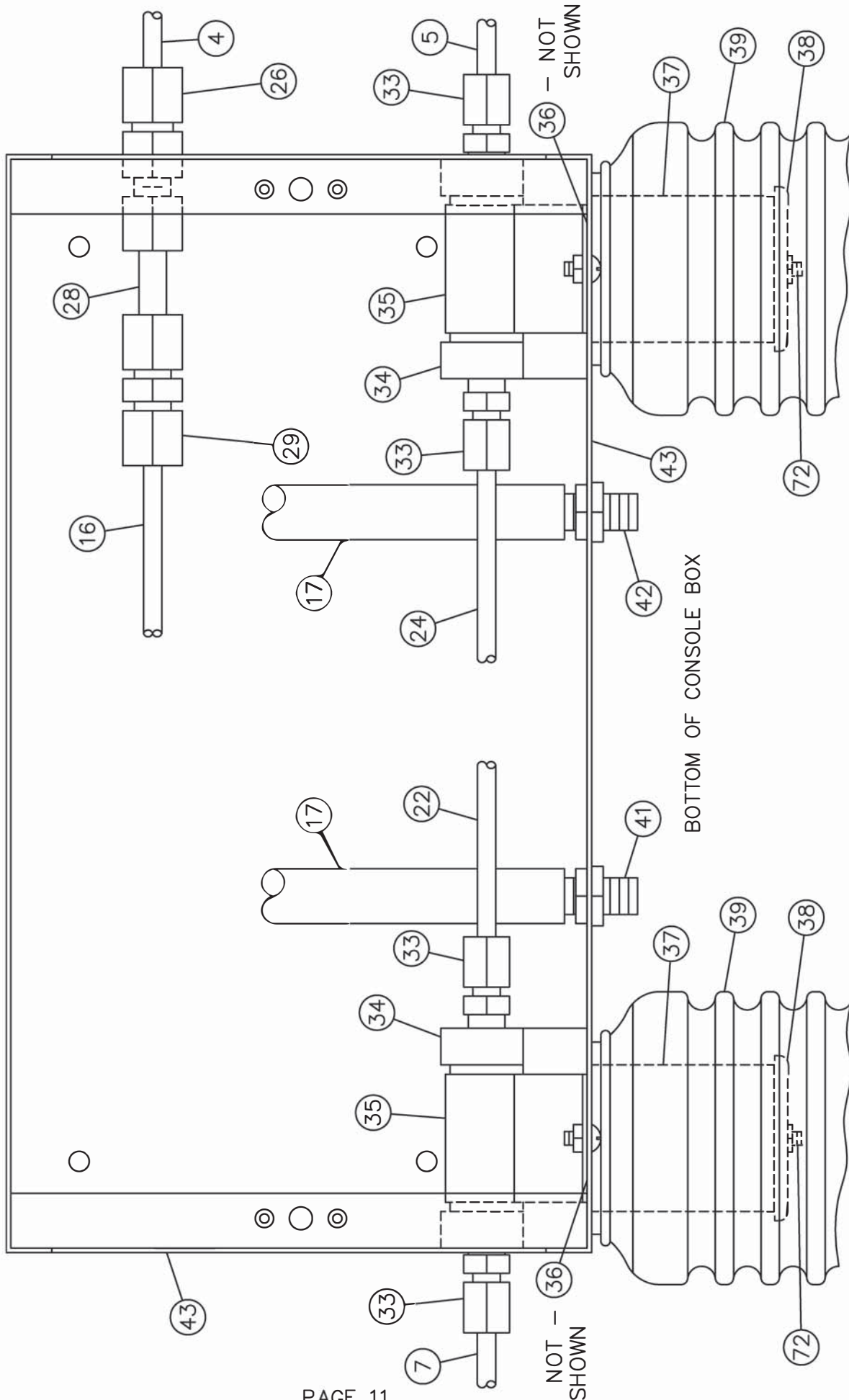

THIS DRAWING IS THE EXCLUSIVE AND CONFIDENTIAL PROPERTY OF GETZ EQ. IT SHALL NOT BE DUPLICATED, USED OR DISCLOSED TO OTHERS WITHOUT THE EXPRESS WRITTEN CONSENT OF GETZ MANUFACTURING.

MATERIAL	FINISH
DWN BY U.A.L.	R.P.R.
SCALE 1/2" = 1"	DATE 7-1-91
TITLE V-2 VACU-FILL BOX INTERIOR	

DWG. NO.	BIN NO.
3G58541-1M	1 OF 1
REV.	
*	

REV	DRAWING CHANGE	BY	ECN NO.	DATE
TOLERANCES UNLESS OTHERWISE SPECIFIED				
FRAC. ±.020	2 PL DEC ±.010	3 PL DEC ±.003		

BOTTOM OF CONSOLE LID

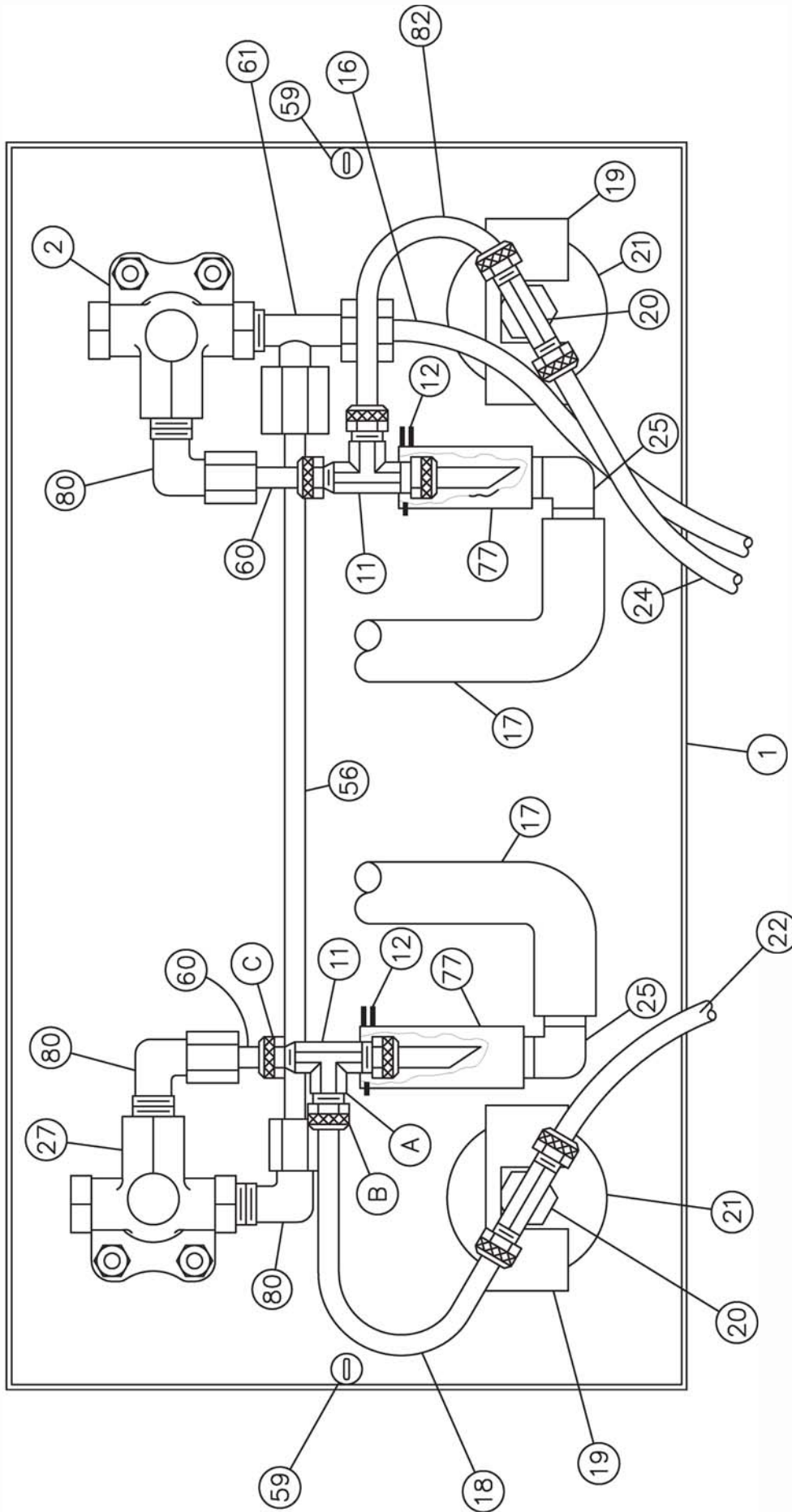

THIS DRAWING IS THE EXCLUSIVE AND CONFIDENTIAL PROPERTY OF GETZ EQ. IT SHALL NOT BE DUPLICATED, USED OR DISCLOSED TO OTHERS WITHOUT THE EXPRESS WRITTEN CONSENT OF GETZ EQUIPMENT.

REV	DRAWING CHANGE	BY	ECN NO.	DATE	MATERIAL	FINISH	SHEET NO.	BIN NO.
					DWN BY U.A.L.	K.P.R.	1 OF 1	
TOLERANCES UNLESS OTHERWISE SPECIFIED							DWG. NO.	REV.
FRAC. ±.020	2 PL DEC ±.010	3 PL DEC ±.003	TITLE				3G58541-2M	*
V-2 CONSOLE LID INTERIOR							GETZ EQUIPMENT INNOVATORS PEKIN, ILLINOIS	

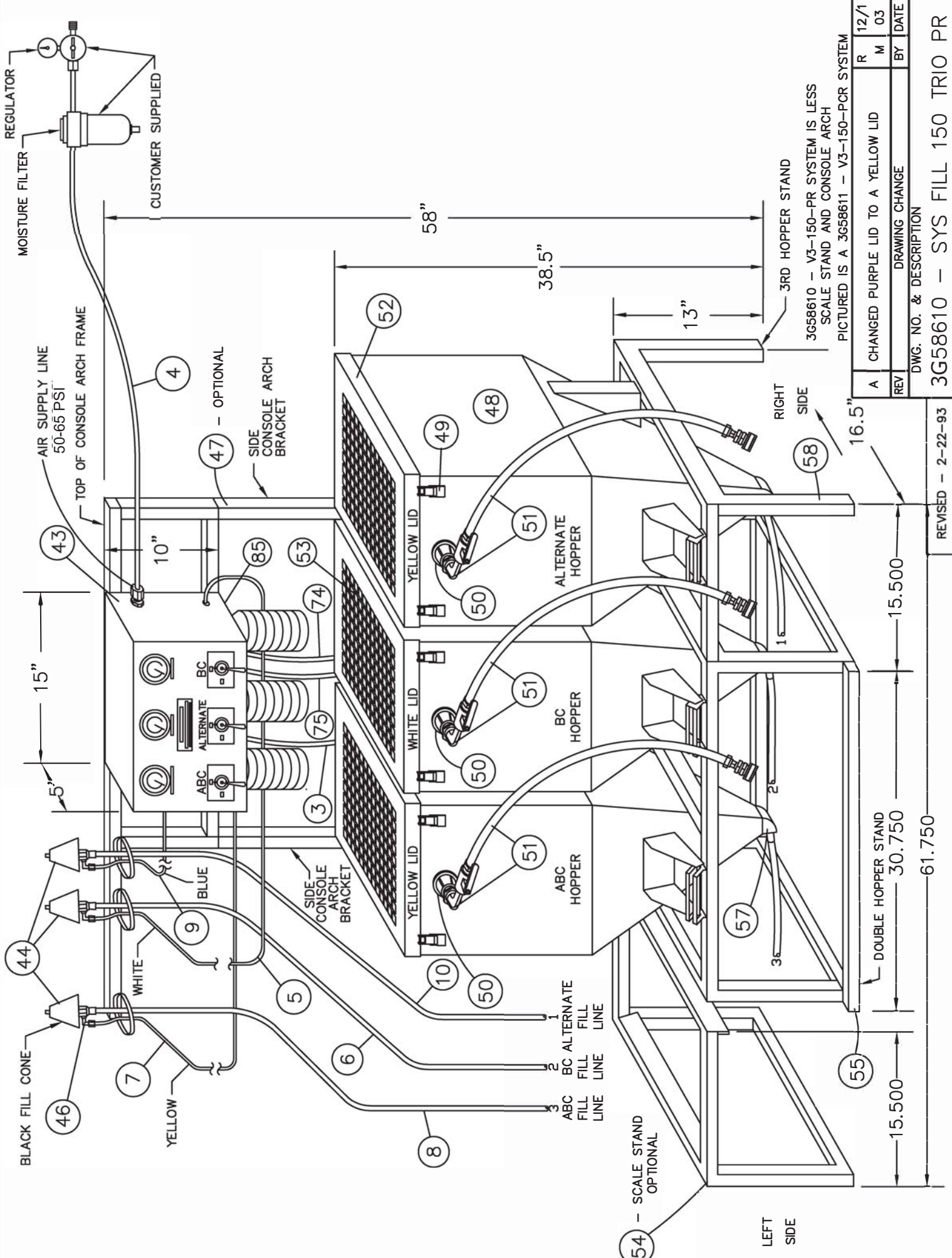

REV	DATE	BY	M	03
A	12/1	R		
DRAWING CHANGE				
DWG. NO. & DESCRIPTION				
3G58610 - SYS FILL 150 TRIO PR				

REVISED - 2-22-93

TOP OF CONSOLE BOX

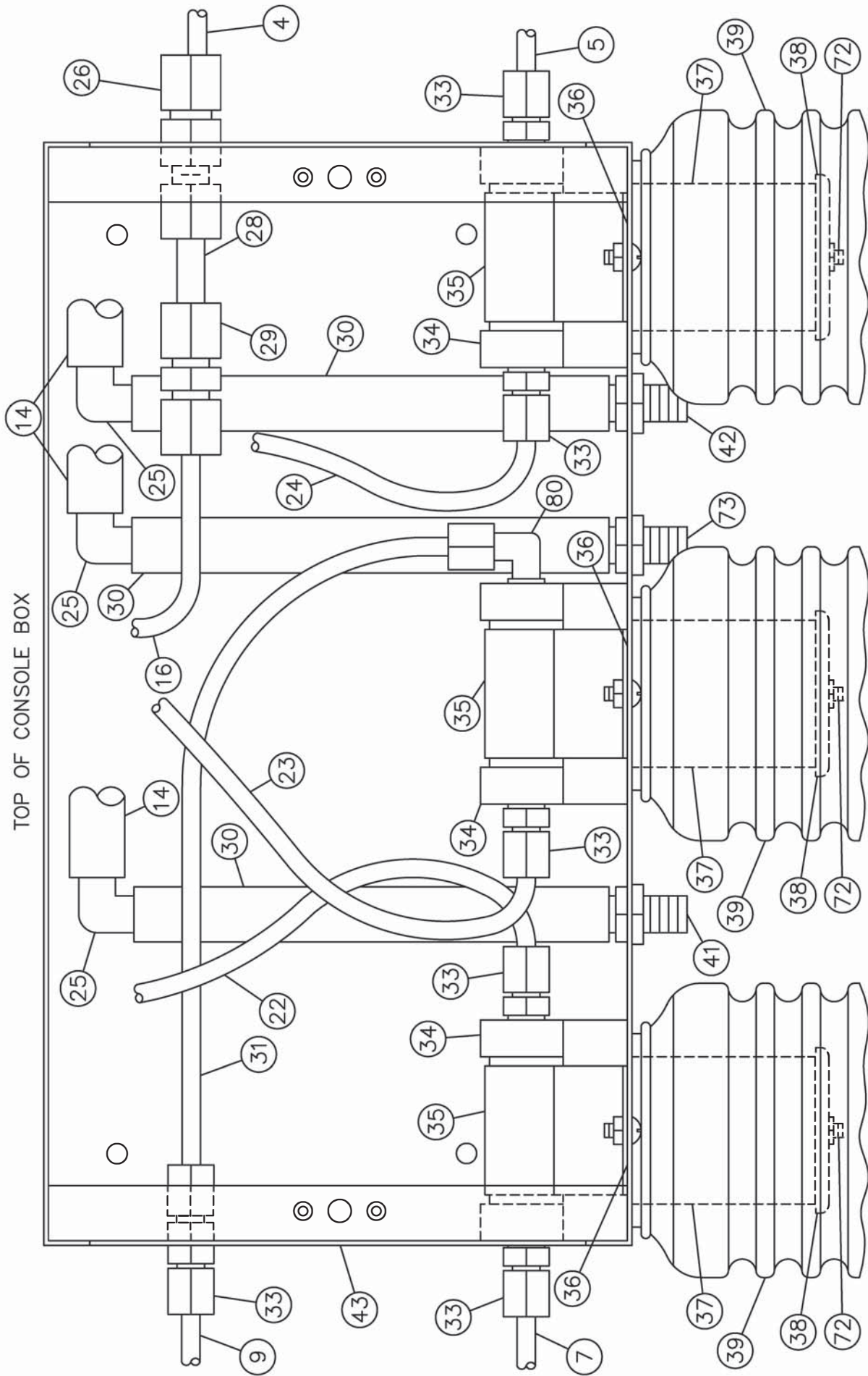

THIS DRAWING IS THE EXCLUSIVE AND CONFIDENTIAL PROPERTY OF GETZ EQ. IT SHALL NOT BE DUPLICATED, USED OR DISCLOSED TO OTHERS WITHOUT THE EXPRESS WRITTEN CONSENT OF GETZ MANUFACTURING.

NOTE: ITEM #36 IS NOT SHOWN

REV	DRAWING CHANGE	BY	ECN NO.	DATE	MATERIAL	FINISH
					DWN BY U.A.L.	R.P.R.
TOLERANCES UNLESS OTHERWISE SPECIFIED				DATE	TITLE	
FRAC. ±.020				2 PL DEC ±.010	3 PL DEC ±.003	V-3 VACU-FILL BOX INTERIOR
				SCALE	DWG. NO.	
				1/2" = 1"	3G58542-1M	
					1 OF 1	BIN NO.
						REV.
						*

BOTTOM OF CONSOLE LID

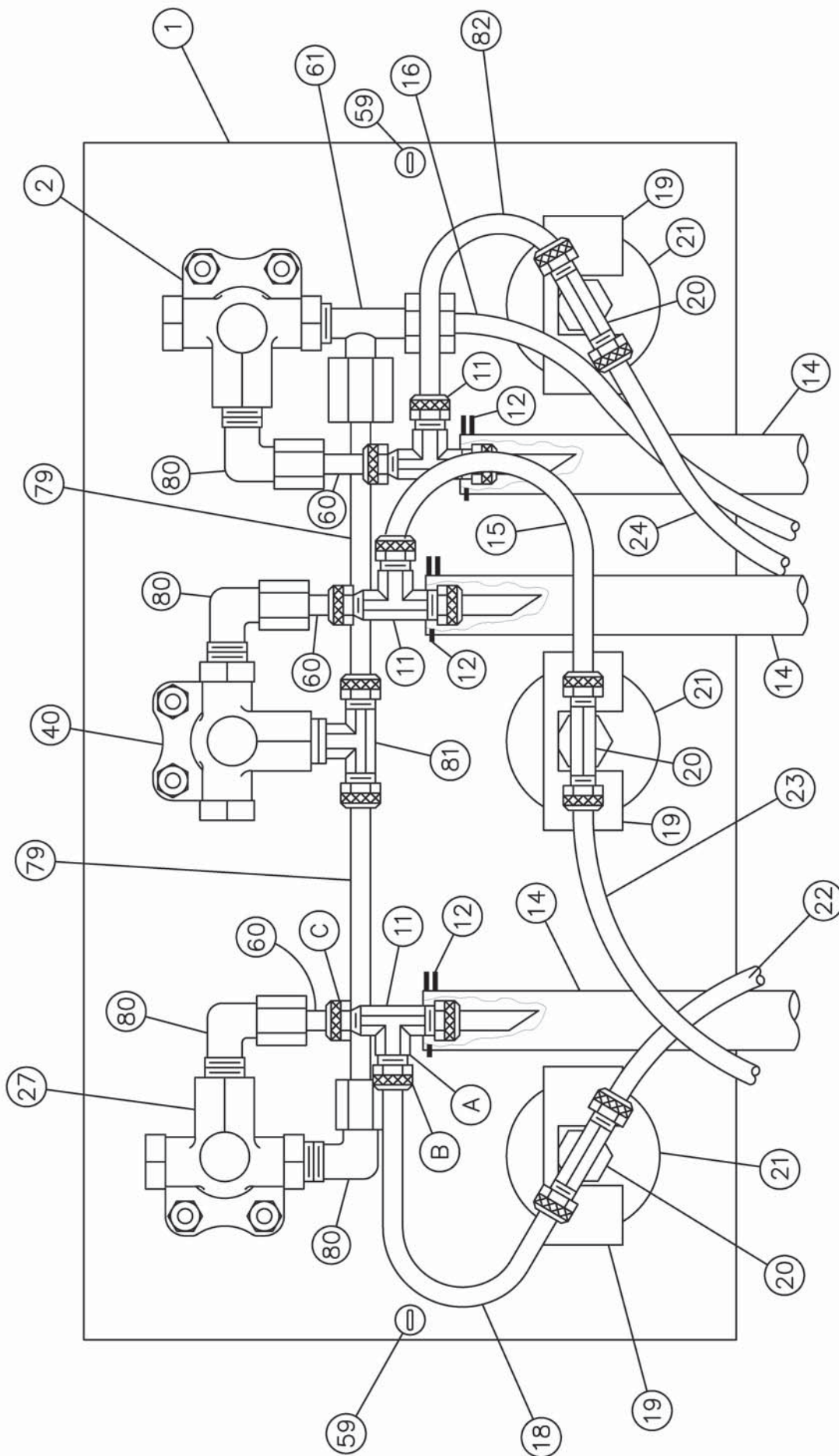

TOP OF CONSOLE LID

THIS DRAWING IS THE EXCLUSIVE AND CONFIDENTIAL PROPERTY OF GETZ EQ. IT SHALL NOT BE DUPLICATED, USED OR DISCLOSED TO OTHERS WITHOUT THE EXPRESS WRITTEN CONSENT OF GETZ EQUIPMENT

REV	DRAWING CHANGE	BY	ECN NO.	DATE	MATERIAL	FINISH
					DWN BY U.A.L.	K.P.R.
TOLERANCES UNLESS OTHERWISE SPECIFIED						
FRAC. ±.020	2 PL DEC ±.010	3 PL DEC ±.003			SCALE 1/2" = 1"	DATE 7-10-91
					TITLE V-3 VACU-FILL LID INTERIOR	
					GETZ EQUIPMENT INNOVATORS PEKIN, ILLINOIS	
					BIN NO. 1 OF 1	
					DWG. NO. 3G58542-2M	
					REV. *	

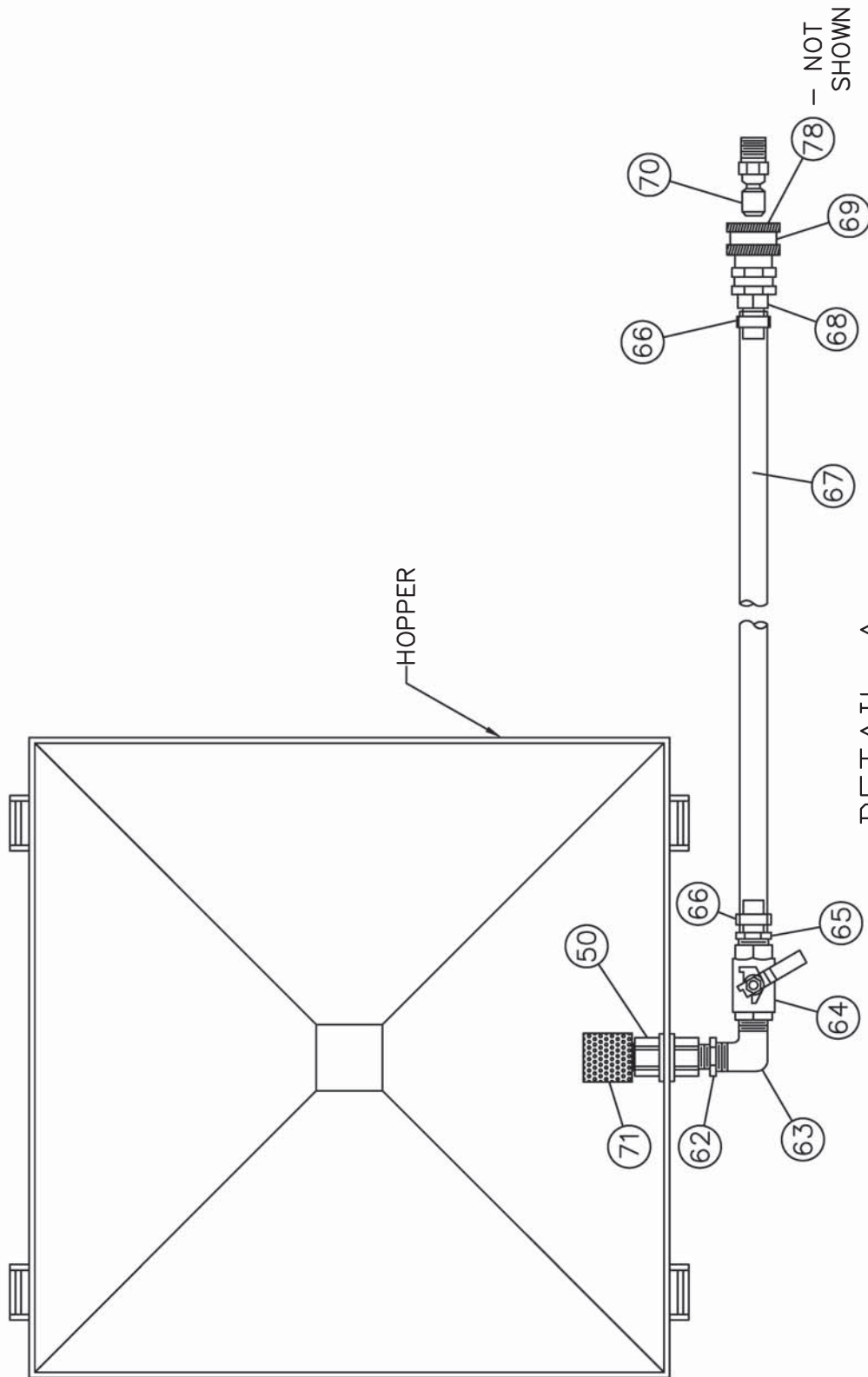

NOTE:

IF PART #67 (NYLON REINFORCED HOSE) BECOMES DISCOLORED, IT MUST BE REPLACED SO OPERATOR CAN VISUALLY INSPECT CHEMICAL.

REPLACEMENT PART #1G0033

DETAIL A

THIS DRAWING IS THE EXCLUSIVE AND CONFIDENTIAL PROPERTY OF GETZ EQ. IT SHALL NOT BE DUPLICATED, USED OR DISCLOSED TO OTHERS WITHOUT THE EXPRESS WRITTEN CONSENT OF GETZ MANUFACTURING.		SHEET NO.	BIN NO.
		1 OF 1	
MATERIAL		GETZ EQUIPMENT INNOVATORS	
FINISH		PEKIN, ILLINOIS	
DWN BY	DATE	TITLE	
K.L.R.		DISCHARGE ASSEMBLY - DETAIL A	
SCALE	DATE		
1/4" = 1"	7-18-91		
FRAC. ±.020	2 PL DEC ±.010	3 PL DEC ±.003	
TOLERANCES UNLESS OTHERWISE SPECIFIED		DWG. NO. 3G58545-M	
		REV. *	

Operating Instructions

Extinguisher Discharge Instructions

1. Place the first extinguisher on a bench or flat surface so the pressure gauge can be seen and the nozzle or hose can be removed. Verify the extinguishers pressure gauge contains enough pressure to allow the contents to be expelled when discharge port and replace it with the proper discharge adapter. If the extinguisher does not contain enough pressure to expel the chemical while discharging, discharge what will come out of the extinguisher and verify the extinguishers pressure gauge reads “0”. Remove the extinguisher valve and either vacuum or pour out the remaining chemical.
2. Look at the extinguishers name plate to determine what type of chemical the extinguisher has in it. Locate the hopper that you want the chemical to go into, either ABC, BC, or alternate. Connect the male quick connect on the discharge adapter that is in the extinguishers discharge valve port to the female quick connect on the discharge assembly (#51) of the proper type and remove the locking seal and pull pin on the extinguisher valve. Verify that the recovery lid on top of the hopper (#48) is clamped securely. Close the ball valve on the discharge assembly and squeeze the valve handle on the extinguisher to release the chemical in the discharge assembly. Inspect the chemical that is contained in the hose of the discharge assembly to verify the chemical is of the proper type shown on the extinguisher name plate and proper for the hopper it is going into. After verifying for proper chemical, open the ball valve on the discharge assembly and release the chemical into the hopper.

Note – If chemical was of the wrong type on inspection, you will need to go ahead and release the chemical into the hopper and discard the contents of the hopper.

3. Verify that all the pressure from the extinguisher has been released into the hopper, then release the extinguisher valve and disconnect the extinguisher discharge adapter away from the discharge assembly (#51). Remove the discharge adapter from the valve of the extinguisher and service the extinguisher to the manufacturer’s recommended procedure.

Extinguisher Recharging Instructions

1. Place the empty extinguisher shell on the scale platform and select the fill line that comes from the hopper that matches the type of chemical the extinguisher name plate requires to the type of chemical in the hopper. Lift the fill line from the ring bracket and place the black fill cone on the end of the fill line into the neck of the extinguisher. Press and twist $\frac{1}{4}$ turn clockwise to seat the fill cone into the extinguisher.
2. With the fill line in the extinguisher either tare the scale to zero or log the weight shown on the scale with the fill line on the extinguisher. Then, add the recommended weight needed for recharging.
3. Located on the console box (#43) is the on-off valve or valves to start the filling process. Turn the on-off valve that corresponds to the chemical in the extinguisher to the "ON" position and watch the scale for increased weight readings. When the scale reads the proper weight of the plastic recovery jar located on the bottom of the console box (below the on-off valve) has chemical coming back into it, shut the on-off valve "OFF". Tap the extinguisher with a rubber hammer to settle the chemical and turn the on-off valve back until proper weight is achieved.
4. Once proper weight is achieved, remove the black fill cone from the extinguisher as you place your finger over the copper tubing in the middle on the black fill cone. Return the fill cone to the ring bracket.
5. Place the extinguisher valve with siphon tube back into the extinguisher and tighten securely.
6. Install a nitrogen recharge adapter into the extinguisher valves discharge port. Set the regulator on the nitrogen supply cylinder to "0" PSI output pressure and connect the female quick coupler on the nitrogen recharge line to the male quick coupler on the nitrogen recharge adapter in the cylinder valve. Squeeze and hold the extinguisher valves discharge lever as you adjust the regulator on the nitrogen supply cylinder to the manufacturer's recommended nitrogen charge pressure. Release the extinguisher valves discharge lever and disconnect the nitrogen line quick coupler from the nitrogen recharge adapter. Place the lock pin and wire on the valve handle and remove the nitrogen recharge adapter. Check the extinguisher valve O-rings for leaks and replace the nozzle of hose onto the extinguisher valves discharge port. Place the inspecting tag on the extinguisher.
7. When ABC, BC, or alternate chemical is needed in the hopper system, lift up on the four (4) lid latches (#49) on the hopper that you need chemical in and pull the latches away from the hopper. Lift up and remove the hopper lid from the hopper. Unscrew the discharge screen (#71) from the Meyer hub (#50) on the inside of the hopper. Grasp the front of the hopper and tilt the hopper toward you as far as you can. Place the open end of the bucket or bag of chemical into the hopper and tilt the hopper back to its upright position carefully. Lift up on the bucket or bag to allow the chemical to stay in the hopper. Reinstall the discharge screen into the Meyer hub and reinstall the hopper lid. Secure the hopper lid with the four (4) lid latches.

Maintenance Schedule

A. Daily Maintenance

1. Empty the plastic overflow jar (#39) when chemical reaches the line on the jar.
2. Inspect the discharge hose or hoses (#67) for weak spots of deterioration by squeezing the full length of hose between your fingers. Check the hose for cuts or tears on the inside and outside. Replace discharge hose if any these conditions are found.

B. Weekly Maintenance

1. Remove the hopper lid or lids from the hopper(s) and vacuum or blow out the powder recovery filter (#53) on each lid with air. Replace recovery filter if chemical will not come off or if the filter material is frayed, causing the filter to leak.
2. Remove the plastic overflow jar or jars (#39) and empty chemical from the jar. Unscrew the filter cap (#38) from the filter holder (#35) while you hold the white filter (#37). Remove white filter and blow out with dry air at 30 PSI. Replace white filter if broken, clogged or the paper on the filter is separating.
3. Inspect the plastic overflow jar (#39) for cracks or chips, especially on the top lip of the threaded end of the jar. Replace if these condition are found.
4. Inspect the fill line or lines coming from the bottom of the hopper(s) up to the black fill cones. Also, check the vacuum lines coming from the black fill cones to the console box (#43) for kinks or cracks. Replace if any of these conditions are found.
5. Inspect black fill cone or cones (#44) for deep grooving, gouges, or tears in the rubber. Replace if any of these conditions are found.
6. Inspect chemical in hopper or hoppers for caking or lumpiness due to excess moisture conditions. Discard chemical if these conditions are found.
7. Inspect the vent line lines (#3, #74, or #75) for restrictions or kinks and replace if any of these conditions are found.
8. Inspect the female quick connect (#69) on the discharge hose or hoses (#51) for leaking or damage. Replace female quick connect u-cup seal (#78) if leaking or discard quick connect if damaged.

Trouble Shooting Guide

Note – Shut off and bleed down the incoming air pressure to the console box before performing any maintenance or repairs to the system.

Problem:

Console box shows good vacuum when checked, but chemical will not flow from hopper to extinguisher.

Solutions:

- A. Black fill cone (#44) is not sealed to top of extinguisher neck:
Remove fill cone and try reseating the fill cone into the extinguisher neck.

- B. Cartridge type extinguisher must have the hole where the cartridge was installed, plugged, and sealed:
Check the nozzle to see if it is sealing.

- C. Chemical in hopper is lumpy or moist and allowing air to enter the fill line:
Loosen the chemical in the hopper by stirring the chemical. Discard the chemical if it is real lumpy.

- D. Fill line on the bottom of the hopper or at the filler tube fitting (#46) is leaking:
Place a clamp on the fill line on the bottom of the hopper and at the filler tube fitting.

- E. Filler tube fitting (#46) or colored vacuum line from console box o filler tube fitting is plugged:
Remove the filler tube fitting from the fill line and colored vacuum line from the console box and blow out with air at 35 PSI.

Note – Never leave vacuum line or filler tube fitting connected to VacuFill system when blowing air down fitting or lines. Permanent damage will result to the VacuFill system.

- F. Fill line from the bottom of the hopper to the filler tube fitting (#46) is plugged: Remove fill line from the hopper and filler tube fitting and blow out with air pressure at no more than 35 PSI. Never blow air down fill line while connected to the hopper.

- G. Colored vacuum line coming from the console box to the filler tube fitting (#46) is leaking or crimped off:
Place the black fill cone (#44) on the fill line that will not flow chemical into an extinguisher. By using some water with soap solution, place a small amount of the solution on the vacuum line where it is held with the plastic nut at the console box and filler tube fitting. Turn the on-off valve on the console box that corresponds to the fill line that will no flow to the “ON” position and watch the soap solution is sucked into the plastic nut, either tighten the plastic nut or replace it with Getz part #1G51590 nut & ferrule.

Problem:

Vacuum gauge on console box shows constant vacuum with the on-off valve in the “ON” position and black fill cone (#44) out of the extinguisher.

Solutions:

- A. The colored vacuum line coming from the console box to the filler tube fitting (#46) may be plugged or kinked:
Remove the colored vacuum line at the console box by removing the plastic nut that holds the line to the console box and slip the colored tubing out of the connector. Turn the console box’s on-off valve to the “ON” position and see if vacuum gauge drops. If the vacuum gauge drops in vacuum to around 3 or 4, you will be assured the trouble is not in the console box. You will need to remove the colored vacuum line from the console box and the filler tube fitting and either blow the line clean with air pressure of no more than 35 PSI or replace the colored tubing if a kink is found. Reinstall the colored line.
- B. Filler tube fitting (#46) may be plugged with chemical:
Remove the filler tube fitting from the fill line and the colored vacuum line. Remove the black fill cone (#44) from the filler tube fitting by unscrewing the black fill cone counter-clockwise as you hold the filler tube fitting. With an air gun set at no more than 35 PSI, blow air around the outside of the copper tube coming from the middle of the filler tube fitting and blow air into the 90 degree plastic elbow that is screwed into the side of the filler tube fitting. Inspect with a light to assure that no chemical or clots remain in the filler tube fitting. Reinstall the filler tube fitting, line, and black fill cone.
- C. Vacuum line or lines inside of the console box may be kinked:
Turn the two cover-locking screws (#59) ½ turn to the right or left with a flat blade screwdriver and remove the console lid carefully. Inspect the plastic colored tubing inside of the console box (#43) for kinked or pinched off lines. Replace the line or lines that are showing a kink as necessary. Replace the console lid onto the console box and turn the locking screws (#59) ½ turn to the left or right.

Checking Control Console for Proper Vacuum Reading

1. Set the incoming supply regulator on the high pressure cylinder or low pressure air compressor to 50 - 65 PSI.
2. Locate the yellow tubing coming from the filler tube fitting (#46) to the lower left side of the console box. Unscrew the plastic nut that holds the yellow tubing to the console box and slip the yellow tubing out of the connector on the console box.
3. Place your finger over the hole in the connector on the console box where the yellow tubing was attached. Turn the ABC on-off valve to the "ON" position and allow the vacuum gauge (#21), located directly above the ABC valve, to increase in gauge reading until it stops. Then, as you watch the vacuum gauge, increase the incoming pressure to the console box by adjusting the incoming supply regulator until the vacuum gauge starts to decrease in reading or 80 PSI is shown on the supply regulators output pressure gauge.

Note – The reading on the vacuum gauge should be 17" or better. This is the 12 to 1 o'clock position on a clock. If this reading is lower than this reading, go to step #4.

4. Unscrew and remove the plastic recovery jar (#39) from the bottom of the console box. Remove the jar gasket (#36) from the jar holder (#34) and inspect for rips, tears, or imperfections. Replace if these conditions are apparent. Reinstall the jar gasket in the jar holder and inspect the top of the plastic recovery jar where it seals to the jar gasket for chips or indentations. Replace if these conditions are found. Reinstall the plastic recovery jar into the jar holder and tighten securely.
5. Recheck vacuum by following step 2 & step 3. If low vacuum is still encountered, proceed to venturi changing instructions on page #23.

Procedure for Changing Venturi Valves on VacuFill Systems

Venturi valves that have been in service for some length of time will sometimes malfunction due to a number of reasons. The following procedure is to be used in order to replace the old venturi valves with new venturi valves:

1. Turn the two cover-locking screws (#59) a half turn and remove the cover so that the inside of the console is exposed.
2. Using a 7/16" open end wrench, unscrew the nut (C) from the venturi.
3. Unscrew the nut (B) and pull venturi from nut (B) & (C).
4. Remove the old venturi (#11) by unscrewing it from the crimped clamp (#12) around the clear vinyl tubing. This will leave the brass nut in the vent tube (#14) and sometimes the 1" piece of clear plastic tube.
5. Remove the brass nut on the new venturi (#11), then the 1/4" clear plastic tube if the 1/4" plastic tube stayed in the vent tube (#14).
6. Place the end of the new venturi that you just removed the brass nut from into the crimped clamp (#12) and screw the venturi into the brass nut held by the crimped clamp. Realign the venturi to match line (#18).
7. Remove (A) & (B) nut off of new venturi and keep for spare parts.
8. Replace hose end (#18), and tighten nut (B).
9. Replace hose end (#60), and tighten nut (C).
10. Replace cover and tighten cover-locking screws (#59).

Suggested Replacement Times on the Major Parts

	<u>Item#</u>	<u>Description</u>	<u>Part#</u>	<u>Time</u>
1.	#67	Discharge Hose	1G0033	6 Months
2.	#53	Lid Filter	1G54040	1 Year
3.	#37	Filter White	1G0067	6 Months
4.	#11	Venturi	1G0021	1 Year
5.	#44	Black Fill Cone	1G51221	2 Years
6.	#69	Female Quick Coupler	1G0028	1 Year
7.	#6	Fill Line	1G0032	2 Years
8.	#8	Fill Line	1G0032	2 Years
9.	#10	Fill Line	1G0032	2 Years
10.	#5	Vacuum Line	1G0048	2 Years
11.	#7	Vacuum Line	1G0047	2 Years
12.	#9	Vacuum Line	1G51550	2 Years
13.	#2	On-Off Valve BC	3G58645	2 Years
14.	#40	On-Off Valve Middle	1G58644	2 Years
15.	#27	On-Off Valve ABC	1G58651	2 Years
16.	#39	Plastic Overflow Jar	1G51436	3 Years

Recommended Maintenance

Dear Customer:

Your recent purchase of our VacuFill system will provide you with many years of dependable service.

Rest assured you have purchased the finest system available in today's marketplace. The advanced engineering and technological advancement employed in the development of this quality product has made it without equal, worldwide.

While this is perhaps the most maintenance-free of any we manufacture, it must be remembered that anything man-made is capable of malfunctioning and may require simple repair.

For this reason, we have put together a maintenance kit which will eliminate the need for delay should your system ever fail. Chances are it won't. Yet, on occasion problem do arise for one reason or another. Call it an extra ounce of security.

I urge your consideration and modest investment in the following. Should you ever experience a problem, chances are you'll be equipped to repair it on the spot.

1 – 3G58900 – KIT SERV & MAINT SV1 & V1 VACU FL

1 – 3G58891 – KIT SERV & MAINT V2 VACU FL

1 – 3G58892 – KIT SERV & MAINT V3 VACU FL

Sincerely,

Getz Equipment Innovators

Note:

Do not modify any components within this system. Any use of parts other than Getz Equipment components exclude all written and implied liabilities.