



A DIVISION OF GETZ FIRE EQUIPMENT

**GETZ EQUIPMENT
INNOVATORS PART NO: 4G58961
MODEL: EP 303 FH
TRIPLE HOSE TESTER
(Revised 5/17/07)**



2320 Lakecrest Drive, Pekin, Illinois 61554
Telephone: 888-747-4389 Fax: 309-495-0625
Website: www.getzequipment.com

Limited Warranty

Products manufactured by Getz Equipment Innovators (with exception of electrical products or components) will be free from defects for a period of one year from shipment date. Electrical products and/or components used in manufactured products will have a (6) month warranty from shipment date. During the warranty period, customers who experience any manufacture-related service issues with our products, the product may be returned for repair or replacement. Customer must contact Getz Equipment for approval prior to any product return. Notwithstanding the foregoing, the limited warranty set forth shall be immediately void of customer uses any replacement parts other than those provided by Getz Equipment Innovators. The warranty does not cover normal wear and tear items, defects resulting from modification, alteration, misuse, exposure to corrosive conditions, extremely high temperatures, improper installation or maintenance. Warranties on component items not manufactured by Getz Equipment Innovators are provided by others whose warranty, evaluation and judgment will be final.

All implied warranties, including, but not limited to, warranties of fitness for purpose and merchantability, are limited to the time periods as stated above. In no event shall Getz Equipment Innovators be liable to incidental or consequential damages. Some states do not allow limitations on how long an implied warranty lasts or the exclusions or limitation of incidental or consequential damages, so that the above limitations or exclusions may not apply to you. Getz Equipment Innovators neither assumes nor authorizes any representative or other person to assume for it any obligation or liability other than as expressly set forth herein.

Mobile Service Vehicles:

The warranty does not cover:

- Defects in the chassis and or power unit
- Defects in separately manufactured products not produced by Getz Equipment Innovators
- Deterioration due to normal wear, tear, and exposure
- Repairs made necessary by negligent use, misuse, abuse, loading the service vehicle beyond its gross vehicle weight limitations, accident, acts of God, or other contingencies beyond the control of Getz Equipment Innovators.
- Repairs deemed necessary by reason of the failure to follow ordinary maintenance procedures.
- Repairs deemed necessary by reason of alterations done without Getz Equipment Innovators' written approval.

Warranty Service:

- All warranty repairs will be performed by Getz Equipment Innovators in Pekin, IL, unless otherwise authorized by Getz Equipment Innovators.

Freight:

- Getz Equipment Innovators will not be liable for shipping or transportation charges to or from customer's location.

This warranty gives you specific legal rights, and you may also have other rights which vary from state to state. To obtain performance to the obligation of the warranty, write to Getz Equipment Innovators, 2320 Lakecrest Drive, Pekin IL 61554, USA for instructions.

**THE GETZ ELECTRIC HYDROTEST PUMP
OPERATION AND PARTS MANUAL
MODEL #EP-303-FH**

TABLE OF CONTENTS

PAGE #

1.....	INSTRUCTIONS
2.....	PARTS LIST
3.....	PARTS LIST (Cont.)
4.....	TOP VIEW DRAWING
5.....	FRONT VIEW DRAWING
6.....	HOSE ADAPTER DRAWING
7.....	MAINTENANCE

INSTRUCTIONS FOR HOSE HYDROTEST PUMP

FOLLOW NFPA 1962 GUIDE LINES WHEN TESTING FIRE HOSES

THIS TESTER IS TO BE POWERED ONLY BY A PROPERLY INSTALLED AND TESTED 120V AC GFCI ELECTRICAL RECEPTICAL

1. Connect a garden hose to a clean water source and purge the line to remove air and dirt.
2. Test the GFCI receptacle before plugging the tester in.

DO NOT TURN THE MOTOR ON AT THIS POINT

3. Roll the hoses out in a straight line in front of the hose tester. This will help reduce the amount of twisting when the hoses are filled with water. Make sure the hoses are on a flat surface with the ends slightly elevated to remove any air trapped inside.
4. Open the water supply to the garden hose and inlet ball valves items # 6, # 46 and #10. Open the ball valve located on the manifold, item # 36. Turn the pump motor on by placing the toggle switch item # 21 in the up position. Run for approx. 30 seconds to purge the tester of air and close item # 36.
5. Close ball valve item # 6. With the pump running, set the test pressure by turning the valve # 31 handle clockwise to increase or counter clockwise to decrease pressure. Close ball valve item # 10 and turn the motor off. Pressure on gauge # 12 must remain at test pressure for five minutes. Release the manifold pressure by opening valve # 36.
6. Select the correct size test adaptor for the hose being tested. Install the test adaptor with the male quick connect on the female end of the hose and connect to item # 9 on the tester manifold. Install the test adaptor with the 1/4" ball valve on the male end of the hose. Turn the ball valve to the on position to remove air trapped in the hose when filled with water.
7. Close valve item # 36 and open valve item # 6 and # 46 to quick fill the hoses. Go to the far end of the hoses being tested and close the 1/4" ball valve when a steady stream of water is present. Allow the hoses to expand from normal water pressure. Place a black mark on each end of the hose, just in back of the coupling.
8. Close valve # 6 and turn the motor on until it reaches test pressure shown on the manifold gauge item #12. Close ball valve # 10 and wait five minutes to ensure pressure remains constant. Close valve # 46, open valve # 10 and relieve the pressure slowly with the bleeder vale # 36 or valves on the hose adaptors.
9. Check the black mark just behind the hose couplings. If the mark has moved away from the fitting; that fitting must be replaced, and the hose must be retested before returning to service.
10. When all pressure has been relieved from the hoses, remove the test adaptors and drain the water from the hoses.

PARTS LIST

<u>DRAWING #</u>	<u>PART #</u>	<u>DESCRIPTION</u>
1	1G51321	FRAME HOSE HYDRO
2	1G53371	MOTOR 60 HZ SINGLE 1 HP
3	1G0102	PIPE TEE BR 1/2 ST
4	1G0309	FTNG SWIVEL WATER
5	1G51948	WATER FILTER N 107
6	1G0084	VLV BALL BR 1/2 X 1/2 FMLE
7	1G0217	PIPE NIP BR 1/2 X CLOSE
8	1G0291	PIPE ELB BR 1/2 ML X 1/2 FMLE
9	1G51823	SOCKET HANSON 1/2 EP 303 FH
10	1G0042	VLV BALL 1/4 X 1/4 ML
11	1G51649	PIPE NIP BR 1/4 CLOSE
12	3G56190	GAUGE 1500 PSI GLY CALIBRATED
13	1G51325	CPLG 3/8 HOSE X 9/16 SWIVEL
14	1G51020	AD 3/8 ML X 9/16 FL (2021)
15	1G51683	PIPE RDCR BR 3/8 X 1/4
16	1G51692	PIPE TEE 3/8 NPT
17	1G53591	ADP VLV UNLOADER
18	1G0291	PIPE ELB BR 1/2 ML X 1/2 FMLE
19	1G0351	PUMP TESTER HOSE
20	1G53972	RELIEF STRAIN 90 DEG
21	1G0358	SWITCH TOGGLE
22	1G51828	SPLASHCOVER SWITCH
23	1G53391	CORD ELECTRICAL

PARTS LIST
(Continued)

<u>DRAWING #</u>	<u>PART #</u>	<u>DESCRIPTION</u>
24	1G52492	AD 1/4 FMLE X 9/16 FL ML
25	1G51325	CPLG 3/8 HOSE X 9/16 SWIVEL
26	1G51412	HOSE 3/8 SYNDFLEX 2250 PSI
27	1G51864	SWIVEL MECH 1/2 (9205)
28	1G51253	CPLG 1/2 ML SYNDFLEX
29	1G51562	MTL SYNDFLEX 1/2 2000 PSI
30	1G51253	CPLG 1/2 ML SYNDFLEX
31	1G0352	VLV UNLOADER AR
32	1G51621	PIPE ELB BR 1/4 FMLE
33	1G53780	HEX NIPPLE 1/4 NPT
34	1G0078	PIPE ELB 45 DEG ST
35	1G53778	MANIFOLD EP/AP TESTER
36	1G0042	VLV BALL 1/4 X 1/4 ML
37	1G51624	PIPE ELB BR 1/4 ST
38	1G51624	PIPE ELB BR 1/4 ST
39	1G0274	VLV PRESS RLF 850 PSI
40	1G53592	CASTER SWIVEL 4"
41	1G53593	CASTER 4"
42	1G51125	BKT MANIFOLD EP 303 FH
43	1G0217	PIPE NIP BR 1/2 X CLOSE
44	1G0103	PIPE RDCR BR 1/2 X 1/4
45	1G0217	PIPE NIP BR 1/2 X CLOSE
46	1G0084	VLV BALL BR X 1/2 X 1/2 FMLE

DETAIL-A

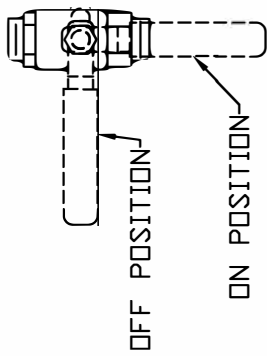

TOP VIEW

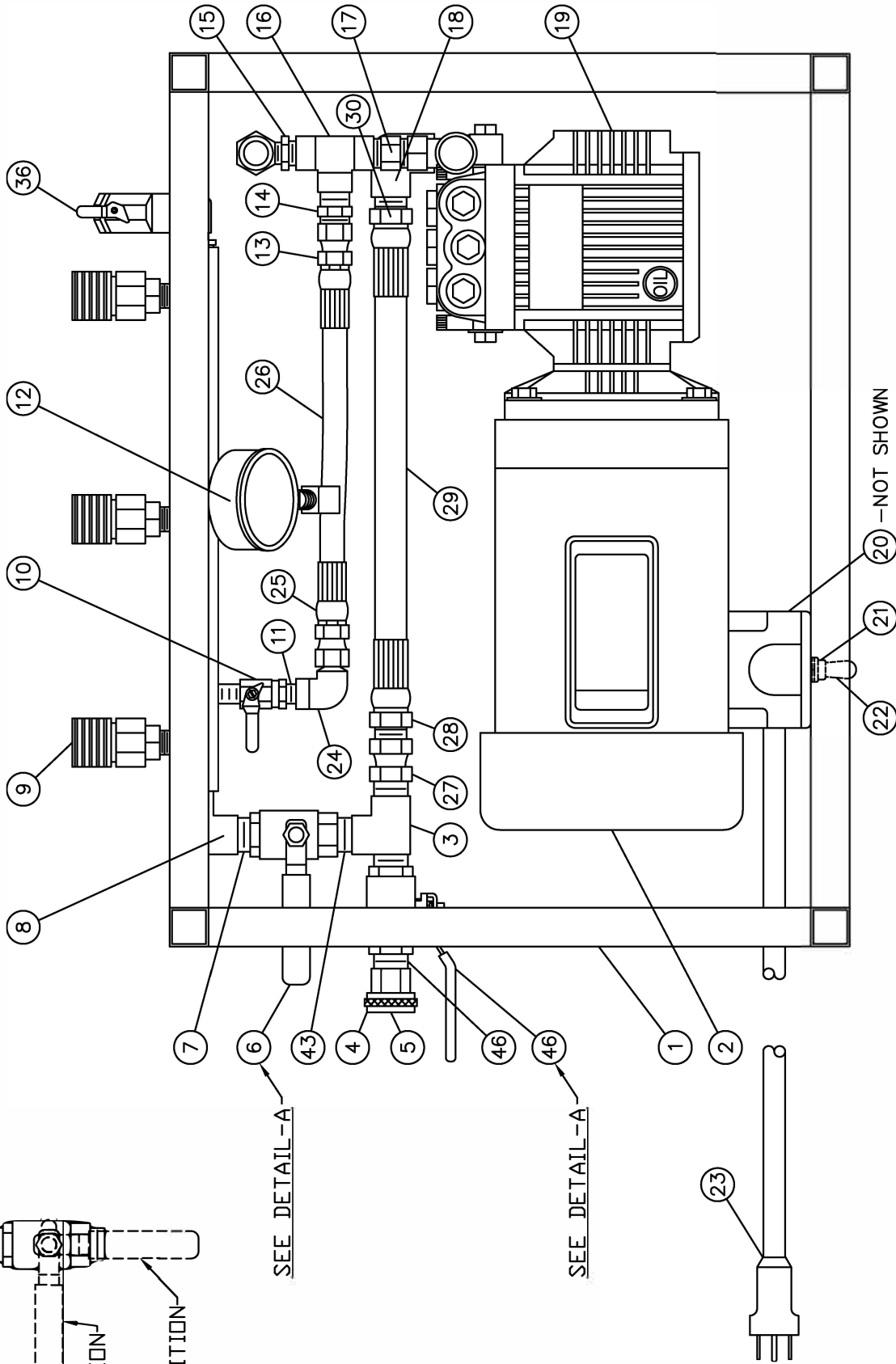

20 - NOT SHOWN

F		CHANGED APPEARANCE OF ITEM 2 CHANGED ITEM 20	C G	5/17 07	THIS DRAWING IS THE EXCLUSIVE AND CONFIDENTIAL PROPERTY OF GETZ MFG. IT SHALL NOT BE DUPLICATED, USED OR DISCLOSED TO OTHERS WITHOUT THE EXPRESS WRITTEN CONSENT OF GETZ MANUFACTURING.		SHEET NO. 1 OF 3		BN NO.	
E		REMOVED ITEM 10, CHANGED MANIFOLD	C G	8/31 05	MATERIAL FINISH		DRAWING CHANGE		DWG. NO. 4G58589-M	
REV		BY R.D.M.		DATE D.C.		TITLE PUMP ELEC/HYDR W/TRI MAN		REV.		F
FRAC. ±.020		2 PL DEC ±.010		3 PL DEC ±.003		SCALE 1/4"=1"		DATE 3-24-92		
TOLERANCES UNLESS OTHERWISE SPECIFIED										
GETZ EQUIPMENT INNOVATORS NORTH PEKIN, ILLINOIS										

FRONT VIEW

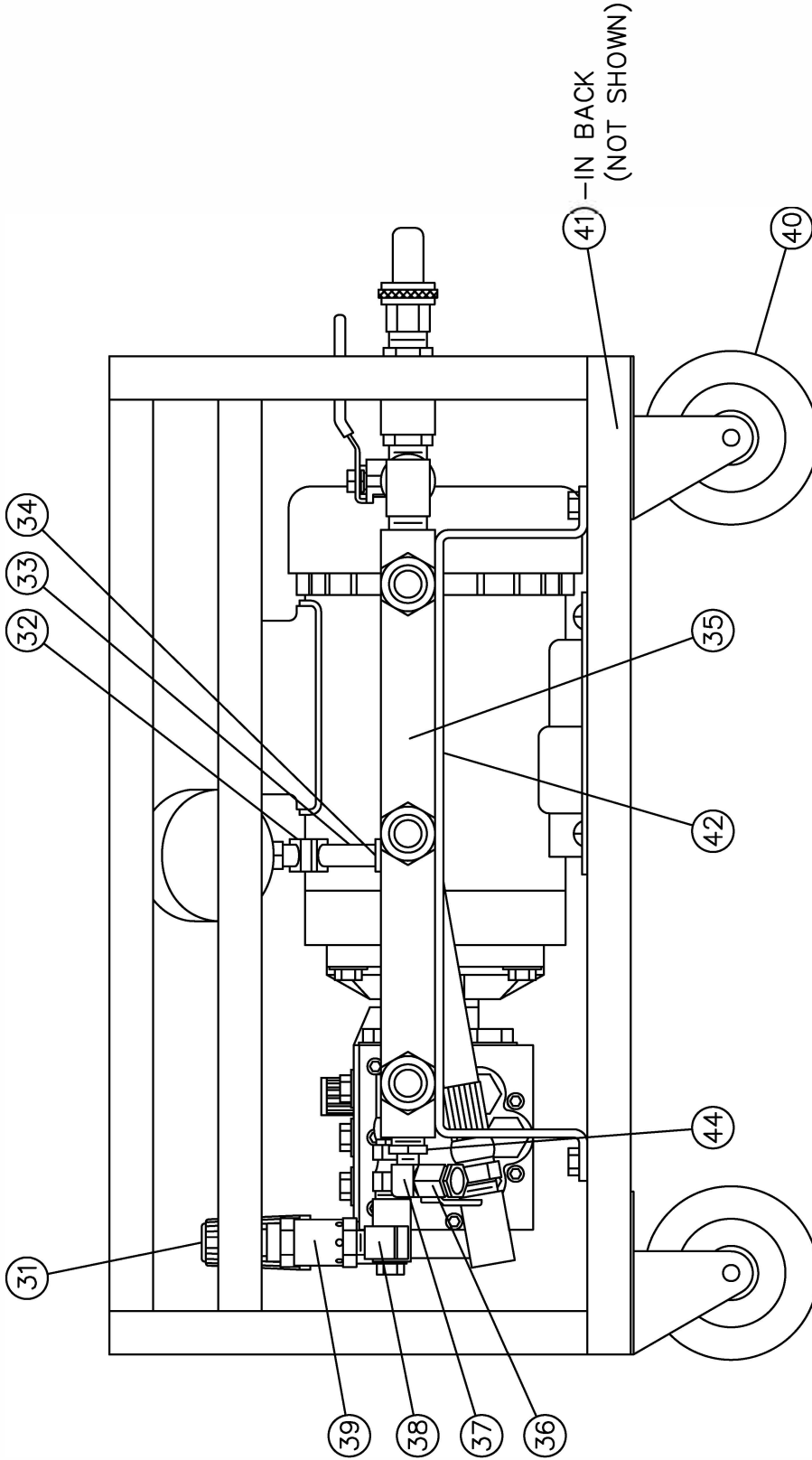

C	OVERALL CHANGE	R	M	4/22	03
B	ADDED ITEM #36	R	M	8/2	00
A	REMOVED ITEM #4	R	M	3/31	00
REV	DRAWN G CHAN	BY	ECN NO.	DATE	
TOLERANCES UNLESS OTHERWISE SPECIFIED					
FRAC.	±020	2 PL	DEC ±0.10	3 R	DEC ±.003

THIS DRAWING IS THE EXCLUSIVE AND CONFIDENTIAL PROPERTY OF GETZ MFG. IT SHALL NOT BE DUPLICATED, USED OR DISCLOSED TO OTHERS WITHOUT THE EXPRESS WRITTEN CONSENT OF GETZ MANUFACTURING.	
MATERIAL	FINISH
DWN BY R.D.M.	CK'D D.C.
SCALE 1/4"=1"	DATE 3-24-92
TITLE PUMP ELEC/HYDR W/TRI MAN	

SHEET NO. 2 OF 3		BIN NO.
DWG. NO. 4G58589-2M		REV. C

GETZ EQUIPMENT INNOVATORS
NORTH PEKIN, ILLINOIS

OPTIONAL

EP-101-FH ONLY

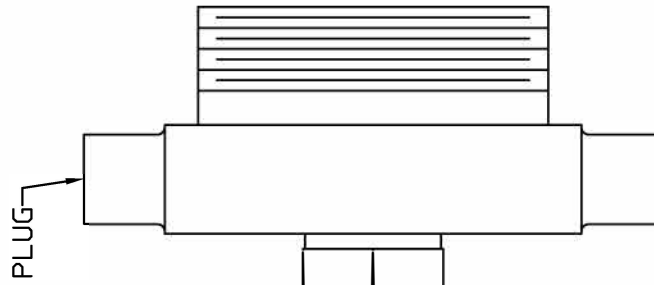
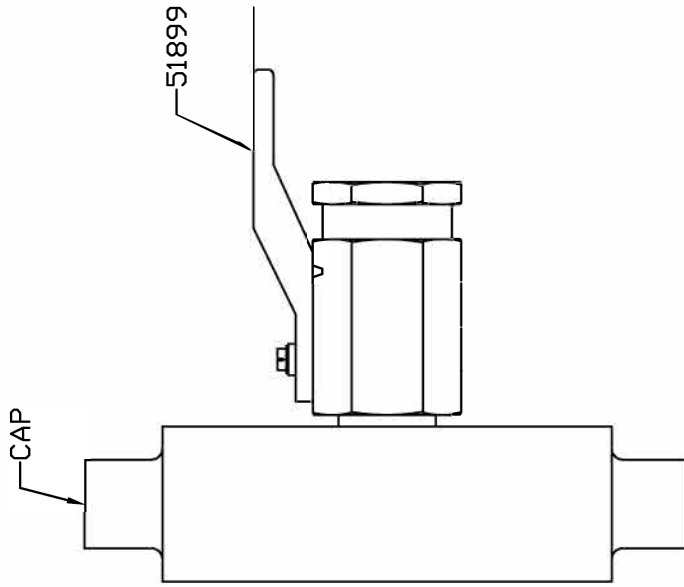
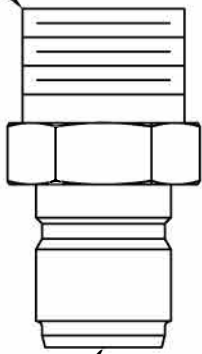

CAPS AVAILABLE

- 3G58523-112 IPT C 1 1/2" IPT CAP WITH BALL VALVE
- 3G58524-112 NST C 1 1/2" NST CAP WITH BALL VALVE
- 3G58525-212 IPT C 2 1/2" IPT CAP WITH BALL VALVE
- 3G58526-212 NST C 2 1/2" NST CAP WITH BALL VALVE

PLUGS AVAILABLE

- 3G58584-112 IPT P 1 1/2" IPT PLUG WITH NIPPLE
- 3G58585-112 NST P 1 1/2" NST PLUG WITH NIPPLE
- 3G58586-212 IPT P 2 1/2" IPT PLUG WITH NIPPLE
- 3G58587-212 NST P 2 1/2" NST PLUG WITH NIPPLE

MAINTENANCE

OIL

SAE 30 W NON DETERGENT

Change after first 50 hours of use, and every 200 hours thereafter.

WINTER STORAGE

If possible store this unit in a warm dry area when not in use.

In conditions where the temperature may drop below freezing, all water must be drained from the system.

WATER LEFT IN THIS SYSTEM CAN CAUSE SEVERE DAMAGE

1. Remove the water hose inlet supply.
2. Open valves # 36, # 46, #10 and # 6.
3. Turn motor on for 30 seconds.

START UP PROCEDURE

1. Inspect for any damage.
2. Check item #23 electrical cord for any cuts or damage. **IF DAMAGED THIS SHOULD BE REPLACED BY A QUALIFIED ELECTRICIAN.**
3. Check item # 20 cord connection. This connection must be tight with no internal wiring exposed.
4. Continue to page 1. Testing