



A DIVISION OF GETZ FIRE EQUIPMENT

GETZ EQUIPMENT INNOVATORS
PART NO.: 3G59615
MODEL: SGL SV150 NEW VACUFILL SYSTEM



2320 Lakecrest Drive, Pekin, Illinois 61554
Telephone: 888-747-4389 Fax: 309-495-0625
Website: www.getzequipment.com

Limited Warranty

Products manufactured by Getz Equipment Innovators (with exception of electrical products or components) will be free from defects for a period of one year from shipment date. Electrical products and/or components used in manufactured products will have a (6) month warranty from shipment date. During the warranty period, customers who experience any manufacture-related service issues with our products, the product may be returned for repair or replacement. Customer must contact Getz Equipment for approval prior to any product return. Notwithstanding the foregoing, the limited warranty set forth shall be immediately void of customer uses any replacement parts other than those provided by Getz Equipment Innovators. The warranty does not cover normal wear and tear items, defects resulting from modification, alteration, misuse, exposure to corrosive conditions, extremely high temperatures, improper installation or maintenance. Warranties on component items not manufactured by Getz Equipment Innovators are provided by others whose warranty, evaluation and judgment will be final.

All implied warranties, including, but not limited to, warranties of fitness for purpose and merchantability, are limited to the time periods as stated above. In no event shall Getz Equipment Innovators be liable to incidental or consequential damages. Some states do not allow limitations on how long an implied warranty lasts or the exclusions or limitation of incidental or consequential damages, so that the above limitations or exclusions may not apply to you. Getz Equipment Innovators neither assumes nor authorizes any representative or other person to assume for it any obligation or liability other than as expressly set forth herein.

Mobile Service Vehicles:

The warranty does not cover:

- Defects in the chassis and or power unit
- Defects in separately manufactured products not produced by Getz Equipment Innovators
- Deterioration due to normal wear, tear, and exposure
- Repairs made necessary by negligent use, misuse, abuse, loading the service vehicle beyond its gross vehicle weight limitations, accident, acts of God, or other contingencies beyond the control of Getz Equipment Innovators.
- Repairs deemed necessary by reason of the failure to follow ordinary maintenance procedures.
- Repairs deemed necessary by reason of alterations done without Getz Equipment Innovators' written approval.

Warranty Service:

- All warranty repairs will be performed by Getz Equipment Innovators in Pekin, IL, unless otherwise authorized by Getz Equipment Innovators.

Freight:

- Getz Equipment Innovators will not be liable for shipping or transportation charges to or from customer's location.

This warranty gives you specific legal rights, and you may also have other rights which vary from state to state. To obtain performance to the obligation of the warranty, write to Getz Equipment Innovators, 2320 Lakecrest Drive, Pekin IL 61554, USA for instructions.

!!!WARNING!!!

SEVERE DAMAGE AND/OR INJURY MAY RESULT

50 & 100 # CAPACITY VACUFILLS:

DO NOT DISCHARGE ANY EXTINGUISHER CYLINDER EXCEEDING 195 PSI AND NOT EXCEEDING 30 POUNDS IN AGENT WEIGHT.

150 # CAPACITY VACUFILLS:

DO NOT DISCHARGE ANY EXTINGUISHER CYLINDER EXCEEDING 195 PSI WITHOUT THE USE OF GETZ MANUFACTURING P/N 59745, WHEELED SYSTEM DISCHARGE ASSEMBLY, INSTALLED.

FAILURE TO INSTALL AND OPERATE EQUIPMENT ACCORDING TO THE GUIDELINES PUT FORTH IN THE INSTRUCTION MANUAL SHALL VOID WARRANTY.

GETZ SGL SV 150 PR VACU-FILL SYSTEM
TABLE OF CONTENTS

PAGE #

1	GETZ SGL SV 50 PR VACU-FILL SYSTEM
2	PARTS LIST
3	DRAWING #1 - GENERAL ARRANGEMENT
4	DRAWING #2 - DISCHARGE ASSEMBLY DETAIL
5	DRAWING #3 - CONSOLE AND FILTER ASSEMBLY
6	DRAWING #4 - CONSOLE LID INTERIOR
7	DRAWING #5 - CONSOLE BODY INTERIOR
8	ASSEMBLY INSTRUCTIONS
9	PROCEDURE FOR DISCHARGING FIRE EXT.
10	PROCEDURE FOR FILLING FIRE EXT.
11	TROUBLE SHOOTING & SERVICE AIDS
12	TROUBLE SHOOTING & SERVICE AIDS - CONT.
13	RECOMMENDED MAINTENANCE KIT

GETZ SV 150

VACU-FILL SYSTEM

MOTIVE POWER SOURCE

AIR COMPRESSOR
COMPRESSED AIR
NITROGEN
CO2 VAPOR

CUSTOMER MUST REMOVE THE SIPHON TUBE FROM THE SUPPLY VALVE OF THE LIQUID CO2 TANK TO HAVE VAPOR.

TO GET THE MAXIMUM PERFORMANCE FROM YOUR VACU-FILL, THE OPERATING INPUT PRESSURE MAY RANGE FROM 50 TO 80 PSI. TO SET YOUR REGULATOR FOR BEST RESULTS, TAKE THE WHITE VACUUM LINE (#5) OUT OF CONNECTOR (#35) ON THE BOTTOM LEFT OUTSIDE CONSOLE. TURN THE ON-OFF VALVE (#19) TO THE "ON" POSITION AND PUT YOUR FINGER OVER CONNECTOR (#35). THEN, ADJUST REGULATOR UP OR DOWN, WHICHEVER IS NEEDED, SO THAT YOU HAVE THE MAXIMUM ON YOUR GAUGE.

CYCLE TIMES TO EXHAUST (OR EMPTY)

5 LB EXTINGUISHER (2.27 KG) = 15 SECONDS
10 LB EXTINGUISHER (4.50 KG) = 25 SECONDS
20 LB EXTINGUISHER (9.00 KG) = 30 SECONDS

CYCLE TIMES TO FILL

5 LB EXTINGUISHER (2.27 KG) = 10 SECONDS
10 LB EXTINGUISHER (4.50 KG) = 15 SECONDS
20 LB EXTINGUISHER (9.00 KG) = 30 SECONDS

SHIPPING SIZE OF CONTAINER

SGL SV 150 PR – 16.5" X 17" X 40"

WARNING: MUST WEAR SAFETY GLASSES

PARTS LIST

<u>DRAWING #</u>	<u>PART #</u>	<u>DESCRIPTION</u>
1	3G58577	POWDER LID RECO
2	3G51407	HOPPER w/STAND 150# SV1
3	3G58545	DCH ASY
4	1G0049	MTL NYCOIL 3/8" WH
5	1G0048	MTL NYCOIL 1/4 WH X 7'
6	1G0032	MTL VINYL TUBE 1/2 CLR X 9'
7	3G51221	CONE FILL
8	3G58539	SV1 CONSOLE COMPLETE
9	1G51484	LID SV1 CONSOLE
10	1G51148	BOX CONSOLE SV1
11	1G0207	STEM FILTER AC-396
12	1G0067	FLTR WH JAR ASSY
13	1G0206	CAP FLTR
14	1G51436	JAR PLASTIC VACU-FILL
15	1G51709	PIPE UNION PLAS 3/8 BLKHD
16	1G0101	CLAMP PLAS HOPPER OUTLET
17	1G0116	CONN PLAS 1/4
18	1G51285	DECAL LEXAN PANEL SV1
19	1G58649	VALVE ON-OFF BR SV1
20	1G0120	PIPE ELB PLAS 1/4ML X 1/4TUBE
21	1G51590	NUT & FERRULE 1/4 PLAS
22	1G54206	PIPE ELB PLAS 1/4 FMLE X 1/2 BARB
23	1G0327	PIPE ELB PLAS 1/8 ML X 1/4 TUBE
24	1G51695	PIPE TEE BR 1/4 BOX
25	1G54040	FLTR LID SLIP-OVER 100/150 HOP
26	1G0099	PIPE ELB PLAS w/BARB
27	1G51680	PIPE RDCR BELL 1/4 X 1/8
28	1G51302	FASTENER LOCKING CONSOLE
29	1G0018	GAUGE 30MG VACUUM
30	1G54189	VENTURI NEW STANDARD
31	XXXXX	NOT USED
32	XXXXX	NOT USED
33	1G51710	PIPE UNION RDCR PLAS 3/8 X 1/4
34	1G0049	MTL NYCOIL 3/8 WH
35	1G51233	CONNECTOR PLAS 1/4FML X 1/4TUB
36	1G0011	BKT FLTR ASY JAR CLP
37	1G0017	FLTR ASY CASTING W/O JAR
38	1G51592	NUT & FERRULE 3/8 PLAS
39	1G51653	PIPE NIP BR 1/4 X 3 1/2
40	1G0205	GASKET JAR
41	1G51789	SCREEN DCH
42	1G51428	HUB MEYER 3/4 FMLE X FMLE
43	1G51682	PIPE RDCR BR 3/4X1/4
44	1G51624	PIPE ELB BR 1/4 ST
45	1G0042	VLV BALL 1/4 X 1/4 ML
46	1G0075	BARB HOSE BR 1/2 X 1/2
47	1G0033	MTL NYLON TUBE DCA1 5/8 - 24"
48	1G0076	BARB HOSE BR 1/2 X 1/4
49	1G0028	CPLG 1/4 FMLE STR THRU
50		NO LONGER USED
51	3G58561	FTNG BR FILLER TUBE COMP
52	1G51469	LATCH HOPPER
53	1G0159	CLAMP BROOM
54	1G0014	BRKT RING
55	1G0591	ELBOW STREET 3/4 90 DEGREE

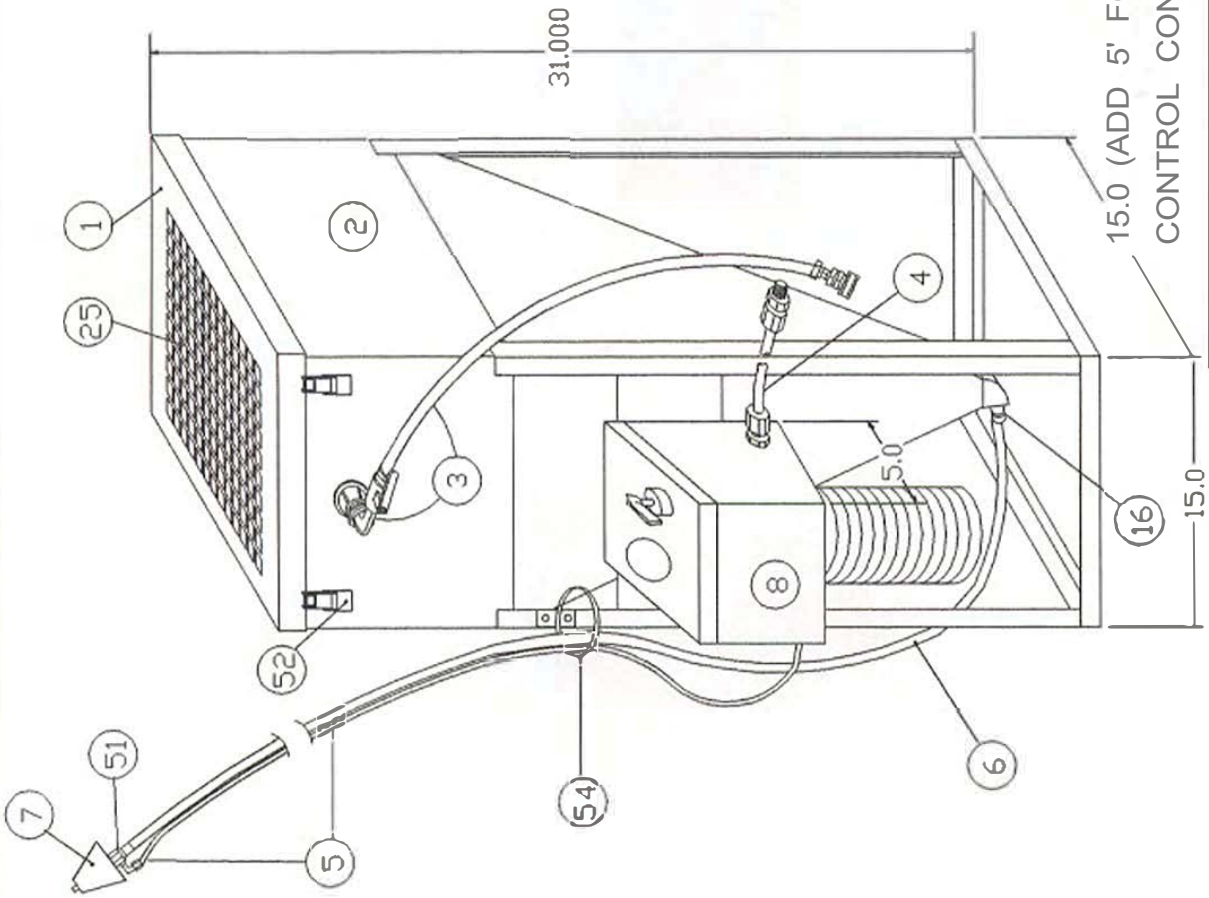

THIS DRAWING IS THE EXCLUSIVE AND CONFIDENTIAL PROPERTY OF GETZ EQ. IT SHALL NOT BE DUPLICATED, USED OR DISCUSSED TO OTHERS WITHOUT THE EXPRESS WRITTEN CONSENT OF GETZ EQUIPMENT

REV	DRAWING CHANGE	BY	ECN NO.	DATE	DWN BY	CK'D	FINISH	DRAWING	BH NO.
					CPG	K.L.R.		1 OF 5	
TOLERANCES UNLESS OTHERWISE SPECIFIED								3G59615-M	REV.
FRAC. ±.020	2 PL DEC ±.010	3 PL DEC ±.003	SCALE	DATE				OPTIMUM PERFORMANCE VACUFILL	*
			1" = 1"	2-5-10					

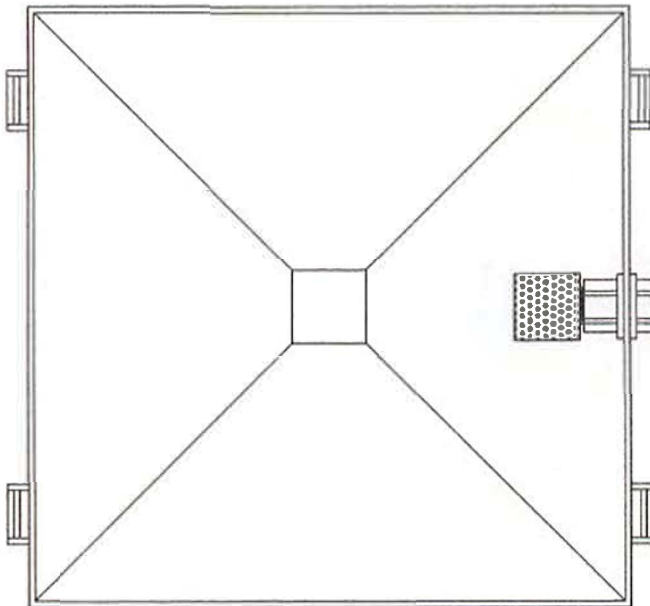

DETAIL A

NOTE:

IF PART #47 (NYLON REINFORCED HOSE) BECOMES DISCOLORED, IT MUST BE REPLACED SO OPERATOR CAN VISUALLY INSPECT CHEMICAL.
 REPLACEMENT PART #1G0033

<small>THIS DRAWING IS THE EXCLUSIVE AND CONFIDENTIAL PROPERTY OF GETZ EQ. IT SHALL NOT BE DUPLICATED, USED OR DISCUSSED TO OTHERS WITHOUT THE EXPRESS WRITTEN CONSENT OF GETZ EQUIPMENT</small>		GETZ EQUIPMENT INNOVATORS PEKIN, ILLINOIS	DRAWING 2 OF 5	<small>BN NO.</small>
<small>MATERIAL</small> CK'D K.L.R.	<small>DATE</small> 2-2-10	<small>SCALE</small> 1/4" = 1"	<small>DMG. NO.</small> 3G59615-2	<small>REV.</small> *
<small>DRAWING CHANGE</small> 2 PL DEC ±010	<small>BY</small> ECN NO.	<small>DATE</small> 3 PL DEC ±.003		
<small>TOLERANCES UNLESS OTHERWISE SPECIFIED</small>				

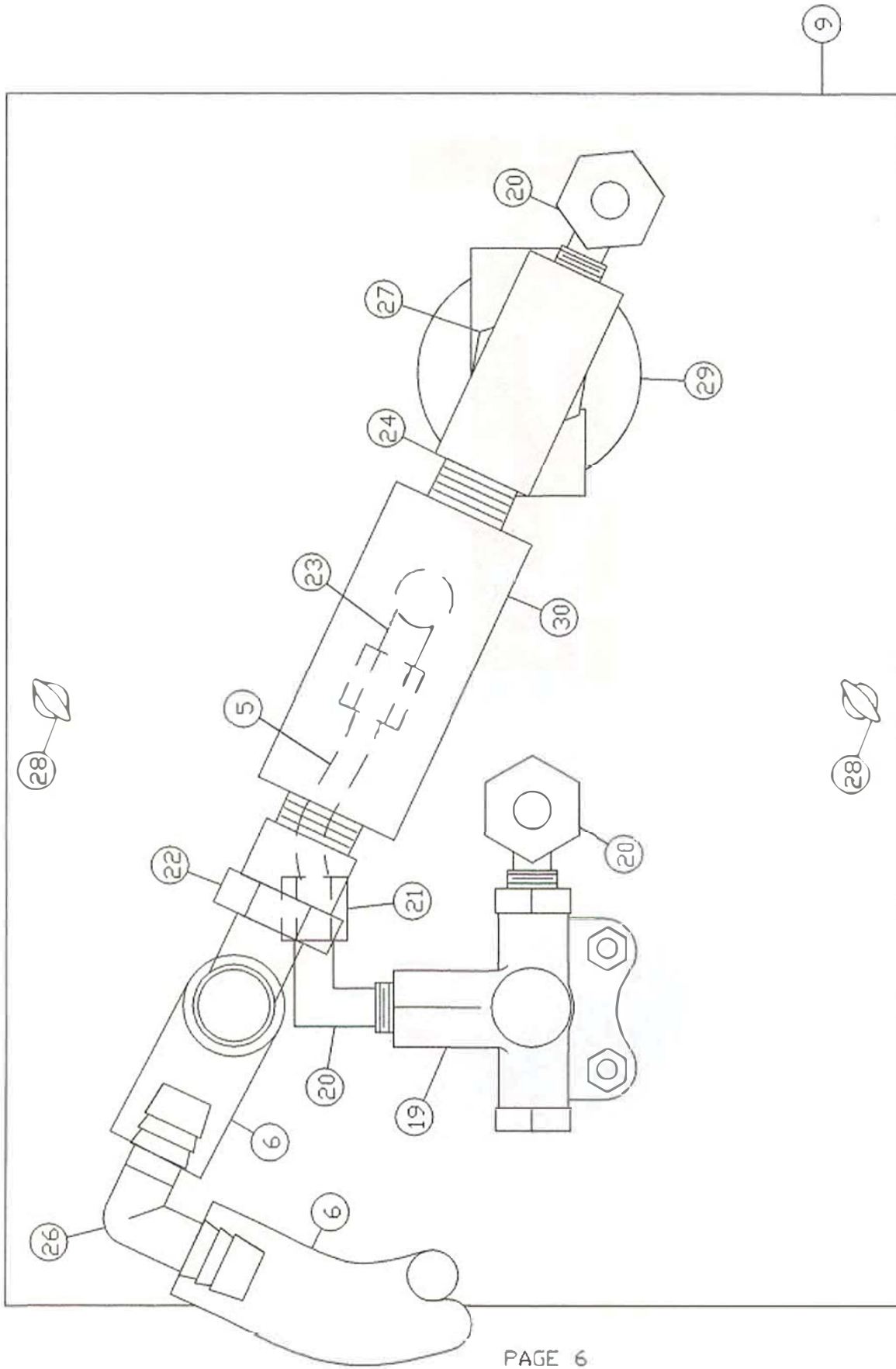

THIS DRAWING IS THE EXCLUSIVE AND CONFIDENTIAL PROPERTY OF GETZ EQ. IT SHALL NOT BE DUPLICATED, USED OR DISCUSSED TO OTHERS WITHOUT THE EXPRESS WRITTEN CONSENT OF GETZ EQUIPMENT

REV	DRAWING CHANGE	BY	ECN NO.	DATE	MATERIAL	FINISH	GETZ EQUIPMENT INNOVATORS PEKIN, ILLINOIS	DRAWING 4 OF 5	BRV NO.
	TOLERANCES UNLESS OTHERWISE SPECIFIED				DWN BY CPG	CK'D K.L.R.			
FRAC. ±.020	2 PL DEC ±.010	3 PL DEC ±.003			SCALE 1"=1'	DATE 12-11-09	VACUFILL CONSOLE - INTERIOR	DWG. NO. 3G59615-4	REV. *

ASSEMBLY INSTRUCTIONS

1. ASSEMBLY UNIT PER DRAWING #1 OF 4 ENCLOSED.
 - A) INSTALL SV1 CONSOLE (#8) TO THE FRONT OF THE HOPPER AND STAND.
** (BOLTS AND NUTS ARE LOCATED IN A PACKAGE IN THE HOPPER.)
 - B) INSTALL RING BRACKET (#54) INTO THE TWO HOLES PROVIDED ON THE FRONT LEFT SIDE OF HOPPER AND STAND.
** (BOLTS AND NUTS ARE LOCATED IN A PACKAGE IN THE HOPPER.)
 - C) INSTALL THE DISCHARGE ASSEMBLY (#3) INTO THE FRONT TOP CENTER 3/4" PORT, MEYER HUB (#42), PROVIDED ON THE FRONT OF HOPPER.
 - D) ASSEMBLE HOSES TO CONSOLE MATCHING NUMBERS ON HOSES TO NUMBERS AT FITTINGS ON CONSOLE.
 - E) ASSEMBLE 1/2" CLEAR HOSE (#6) TO THE 45 DEGREE HOPPER OUTLET ON BOTTOM OF HOPPER.

NOTE: YOU WILL FIND IT MUCH EASIER TO GET THE HOSE ON THE BOTTOM OF HOPPER IF YOU PREHEAT THE END OF HOSE IN A CUP OF VERY HOT WATER.
 - F) ATTACH THE 6' PIECE OF 1/2" TUBING TO THE VENT HOSE CONNECTION WHICH IS THE BLACK PLASTIC NIPPLE ON THE BOTTOM OF THE CONSOLE. THIS IS AN AIR VENT LINE.
 - G) ATTACH CONNECTOR (#17) FROM RIGHT HAND SIDE OF THE CONSOLE TO YOUR REGULATED AIR SUPPLY. (APPROXIMATELY 65 PSI)
2. APPLY PRESSURE TO THE CONSOLE AND ADJUST YOUR REGULATOR FOR APPROXIMATELY 50 TO 80 PSI. (SEE PAGE 1 FOR PROPER REGULATOR SETTING.)

PORTABLE EXTINGUISHER DISCHARGE INSTRUCTIONS

1. MAKE SURE THE PORTABLE EXTINGUISHER IS PRESSURIZED.
2. IF PORTABLE EXTINGUISHER IS NOT PRESSURIZED, AND IS FULL OR PARTIALLY FULL OF CHEMICAL, DISCHARGE THE CONTENTS OF THE EXTINGUISHER INTO THE HOPPER SYSTEM AND POUR OUT OR VACUUM THE REMAINING CHEMICAL FROM THE EXTINGUISHER.
3. CONNECT PROPER DISCHARGE ADAPTER WITH MALE QUICK COUPLER (#50) INTO VALVE ASSEMBLY OF EXTINGUISHER.
4. CONNECT DISCHARGE ASSEMBLY HOSE (#3) TO THE DISCHARGE ADAPTER (#50) ON EXTINGUISHER.
5. MAKE SURE THE POWDER RECOVERY LID IS PROPERLY CLAMPED TO HOPPER.
6. CLOSE VALVE (#45) AND PARTIALLY DISCHARGE EXTINGUISHER INTO THE DISCHARGE HOSE (#47) TO INSPECT CHEMICAL.
7. IF CHEMICAL APPEARS TO BE OK, YOU MAY OPEN VALVE (#45) WHICH WILL LET THE CHEMICAL ENTER THE HOPPER AND ALLOW NITROGEN PRESSURE TO ESCAPE THROUGH THE POWDER RECOVERY FILTER.
8. AFTER THE EXTINGUISHER'S PRESSURE GAUGE HAS REACHED ZERO, YOU MAY DISCONNECT THE DISCHARGE ASSEMBLY HOSE (#3) AND PROCEED TO INSPECT OR HYDROTEST THE EXTINGUISHER.
9. REMOVE VALVE FROM EXTINGUISHER AND CLEANING:
 - A. CLEAN ALL POWDER OUT OF THREADS OF NECK OF EXTINGUISHER. (USE A TOOTHBRUSH).
 - B. CLEAN INTERIOR OF VALVE ASSEMBLY AND VALVE STEM. (THIS IS VERY IMPORTANT TO MAKE SURE EXTINGUISHER DOES NOT LEAK OFF).
 - C. CLEAN THREADS ON VALVE ASSEMBLY AND CLEAN AND LUBRICATE O-RING.
 - D. REFILL THE EXTINGUISHER WITH CHEMICAL. (SEE PAGE 10)

FILLING EMPTY DRY CHEMICAL EXTINGUISHERS

1. MAKE SURE SCALE IS PERFECTLY SET AND BALANCED TO ZERO.
2. MAKE SURE EMPTY DRY CHEMICAL EXTINGUISHER IS VISUALLY CHECKED ON THE INSIDE FOR DRYNESS AND CORROSION WITH INSPECTION LIGHT.
3. CHECK LABEL ON EMPTY EXTINGUISHER FOR TYPE OF CHEMICAL TO BE FILLED WITH.
4. THE FILLING LINES ARE ALSO COLORED YELLOW AND WHITE, SO YOU KNOW YELLOW IS ABC AND WHITE IS BC CHEMICAL.
5. SET EMPTY EXTINGUISHER ON SCALE AND CHECK PROPER WEIGHT TO BE FILLED ON EXTINGUISHER LABEL.
6. ONCE PROPER CHEMICAL IS DETERMINED, TAKE YELLOW OR WHITE FILLING LINE AND EXTEND IT TO THE TOP OF THE EMPTY CYLINDER TO BE FILLED.
7. TAKE THE RUBBER CONE (#7) ON THE END OF THE FILLING LINE (#6) AND PLACE INTO TOP OF CYLINDER NECK WITH A 1/4 TURN CLOCKWISE.
8. SCALE: TWO WAYS OF WEIGHING EXTINGUISHER FOR PROPER FILLING:
 - A. WITH EXTINGUISHER AND FILLING LINE ATTACHED ON SCALE, RETURN SCALE BACK TO ZERO AND PROCEED TO FILL TO RECOMMENDED WEIGHT.
 - B. WITH EXTINGUISHER AND FILLING LINE ATTACHED ON SCALE, YOU CAN ADD RECOMMENDED WEIGHT TO THE WEIGHT READING OF EXTINGUISHER AND FILL LINE PRESENTLY ON SCALE.
9. TURN ON-OFF VALVE (#19) TO THE "ON" POSITION UNTIL EXTINGUISHER REACHES RECOMMENDED WEIGHT. THEN TURN VALVE TO "OFF" POSITION ONCE EXTINGUISHER IS FILLED. (IF CHEMICAL RETURNS TO PLASTIC JAR BEFORE REACHING PROPER WEIGHT, LET CHEMICAL SETTLE THEN TURN VALVE BACK TO "ON" TO GET RECOMMENDED WEIGHT).
10. REMOVE FILLING LINE CONE (#7) FROM NECK OF EXTINGUISHER TO FILLING LINE RING BRACKET.

TROUBLE SHOOTING AND SERVICE AIDS

1. CHEMICAL WILL NOT FLOW WHEN:

- A. EXTINGUISHER IS NOT VACUUM TIGHT. (i.e., A CARTRIDGE EXTINGUISHER WITH A LEAKY CARTRIDGE RECEIVER.)
- B. THERE IS A KINK IN A HOSE.
- C. THE FILLING LINE AND/OR VACUUM LINE ARE CLOGGED.

NOTE: NEVER BLOW AIR PRESSURE INTO THE VACU-FILL CONSOLE OR JAR ASSEMBLY. MAY CAUSE INJURY OR DAMAGE TO THE CONSOLE.

- D. JAR FILTER ASSEMBLY ON CONSOLE IS NOT PROPERLY SEALED. (JAR MUST BE SCREWED ON TIGHT.)
 - E. AIR SUPPLY IS NOT REGULATED AND MAINTAINED AT 50 TO 80 PSI.
2. FILTER JARS LOCATED UNDER CONSOLE SHOULD NEVER BE ALLOWED TO FILL MORE THAN HALF WAY BEFORE EMPTYING.
- A. FILTER ELEMENT IN JARS MAY BE BLOWN CLEAN WITH AN AIR GUN OR SIMILAR DEVICE WEEKLY. REPLACE JAR FILTER EVERY SIX MONTHS.
3. THE ON/OFF VALVE (#19) ON THE CONSOLE MAY, AFTER A PERIOD OF TIME, TEND TO TIGHTEN UP OR BECOME HARDER TO OPERATE.
- A. FIRST THING SHUT OFF AIR PRESSURE TO CONSOLE AND BLEED OUT ALL PRESSURE IN THE SYSTEM.
 - B. TO DISMANTLE VALVE (#19), SIMPLY LOOSEN THE NUT OR CAP AROUND THE STEM, (COUNTER-CLOCKWISE) AND USING THE HANDLE, TURN TO "ON" POSITION AND PULL ENTIRE STEM, NUT AND BUSHING OUT OF THE VALVE BODY. NOTE THE POSITION OF THE KEY JUST BEHIND THE SPRING SO YOU CAN REASSEMBLE VALVE CORRECTLY.

(SEE PAGE 5)

USING CARBURETOR CLEANER OR SIMILAR CLEANER, CLEAN INNER VALVE BODY AND THE BUSHING WITH THREE HOLES IN IT.

PUT A THIN FILM OF LUBRIPLATE, OR SIMILAR LUBRICANT, ON BOTH PARTS.

PULL THE SMALL INNER "O" RING AND THE SPRING TOWARDS THE HANDLE AND REASSEMBLE VALVE, MATING KEY WASHER IN THE VALVE SLOT. (THE SMALL O-RING SEALS AND PREVENTS LEAKS AROUND STEM.)

TROUBLE SHOOTING AND SERVICE AIDS

(CONTINUED)

TO DETERMINE IF THE PROBLEM IS IN THE CONSOLE, REMOVE VACUUM LINE (#5) FROM CONNECTOR (#35) LOCATED ON LOWER LEFT SIDE OF CONSOLE.

NOW, WITH THE VACUUM LINE (#5) REMOVED FROM THE OUTSIDE OF CONSOLE, PLACE YOUR FINGER OVER THE FITTING, (#35), ON THE OUTSIDE OF THE CONSOLE AND TURN ON THE VALVE. YOU SHOULD FEEL SUCTION HERE, AND THE GAUGE SHOULD READ OVER 15" OF VACUUM. IF NOT, MAKE SURE JAR GASKET IN (#37) IS IN PLACE AND MAKE SURE THE JAR IS TIGHT AGAINST GASKET.

DO NOT BLOW AIR THROUGH CONSOLE OR JAR ASSEMBLY

JAR IS LIKELY TO EXPLODE IF SUBJECT TO MORE THAN 5 PSI

IF YOU HAVE SUCTION AT FITTING (#35), YOU CAN BE ASSURED THAT THE TROUBLE IS NOT IN THE CONSOLE.

MOST COMMON PROBLEMS OUTSIDE THE CONSOLE ARE: LUMPY CHEMICAL, MOIST CHEMICAL, AND A PLUGGED FILLING HOSE.

RECOMMENDED MAINTENANCE KIT

DEAR CUSTOMER:

YOUR RECENT PURCHASE OF OUR VACU-FILL SYSTEM WILL PROVIDE YOU WITH MANY YEARS OF DEPENDABLE SERVICE.

REST ASSURED YOU HAVE PURCHASED THE FINEST SYSTEM AVAILABLE IN TODAY'S MARKETPLACE. THE ADVANCED ENGINEERING AND TECHNOLOGICAL ADVANCEMENT EMPLOYED IN THE DEVELOPMENT OF THIS QUALITY PRODUCT HAS MADE IT WITHOUT EQUAL, WORLDWIDE.

WHILE THIS SYSTEM IS PERHAPS THE MOST MAINTENANCE-FREE OF ANY WE MANUFACTURE, IT MUST BE REMEMBERED THAT ANYTHING MAN-MADE IS CAPABLE OF MALFUNCTIONING AND MAY REQUIRE SIMPLE REPAIR.

FOR THIS REASON, WE HAVE PUT TOGETHER A MAINTENANCE KIT WHICH WILL ELIMINATE THE NEED FOR DELAY SHOULD YOUR SYSTEM EVER FAIL. CHANCES ARE IT WON'T. YET, ON OCCASION PROBLEMS DO ARISE FOR ONE REASON OR ANOTHER. CALL IT AN EXTRA OUNCE OF SECURITY.

I URGE YOUR CONSIDERATION AND MODEST INVESTMENT IN THE FOLLOWING. SHOULD YOU EVER EXPERIENCE A PROBLEM, CHANCES ARE YOU'LL BE EQUIPPED TO REPAIR IT ON THE SPOT.

1 - 3G59634 - KIT SERV & MAINT SV1 100/150 NEW

SINCERELY,

Getz Equipment Innovators

NOTE:

DO NOT MODIFY ANY COMPONENTS WITHIN THIS SYSTEM. ANY USE OF PARTS OTHER THAN GETZ EQUIPMENT COMPONENTS EXCLUDES ALL WRITTEN AND IMPLIED LIABILITIES.