



**Getz Equipment Innovators
450 lb Wheeled Unit
Dry Chemical Fill System
3G0070**

Revised 9/9/16



2320 Lakecrest Drive, Pekin, Illinois 61554
Telephone: 888-747-4389 Fax: 309-495-0625
Website: www.getzequipment.com

Limited Warranty

Products manufactured by Getz Equipment Innovators (with exception of electrical products or components) will be free from defects for a period of one year from shipment date. Electrical products and/or components used in manufactured products will have a (6) month warranty from shipment date. During the warranty period, customers who experience any manufacture-related service issues with our products, the product may be returned for repair or replacement. Customer must contact Getz Equipment for approval prior to any product return. Notwithstanding the foregoing, the limited warranty set forth shall be immediately void of customer uses any replacement parts other than those provided by Getz Equipment Innovators. The warranty does not cover normal wear and tear items, defects resulting from modification, alteration, misuse, exposure to corrosive conditions, extremely high temperatures, improper installation or maintenance. Warranties on component items not manufactured by Getz Equipment Innovators are provided by others whose warranty, evaluation and judgment will be final.

All implied warranties, including, but not limited to, warranties of fitness for purpose and merchantability, are limited to the time periods as stated above. In no event shall Getz Equipment Innovators be liable to incidental or consequential damages. Some states do not allow limitations on how long an implied warranty lasts or the exclusions or limitation of incidental or consequential damages, so that the above limitations or exclusions may not apply to you. Getz Equipment Innovators neither assumes nor authorizes any representative or other person to assume for it any obligation or liability other than as expressly set forth herein.

Mobile Service Vehicles:

The warranty does not cover:

- Defects in the chassis and or power unit
- Defects in separately manufactured products not produced by Getz Equipment Innovators
- Deterioration due to normal wear, tear, and exposure
- Repairs made necessary by negligent use, misuse, abuse, loading the service vehicle beyond its gross vehicle weight limitations, accident, acts of God, or other contingencies beyond the control of Getz Equipment Innovators.
- Repairs deemed necessary by reason of the failure to follow ordinary maintenance procedures.
- Repairs deemed necessary by reason of alterations done without Getz Equipment Innovators' written approval.

Warranty Service:

- All warranty repairs will be performed by Getz Equipment Innovators in Pekin, IL, unless otherwise authorized by Getz Equipment Innovators.

Freight:

- Getz Equipment Innovators will not be liable for shipping or transportation charges to or from customer's location.

This warranty gives you specific legal rights, and you may also have other rights which vary from state to state. To obtain performance to the obligation of the warranty, write to Getz Equipment Innovators, 2320 Lakecrest Drive, Pekin IL 61554, USA for instructions.

Getz Equipment Innovators
450 ABC Dry Chemical Fill System

Table of Contents

Page

3	Getz Equipment Filling System
4	Parts List
5	Drawing #2 – Console & Filter Assembly
6	Drawing #3 – Console Lid Interior
7	Parts List
8	Drawing #3 – General Arrangement
9	Assembly Instructions
10	Procedure For Discharging Fire Extinguisher
10	Procedure For Filling Fire Extinguisher
11	Trouble Shooting & Service Aids
11	Recommended Spare Parts Kit
12	Maintenance Kit Instructions

Getz Equipment Filling System

Power Source:

Air Compressor

Compressed Air

Nitrogen

CO2 Vapor *

* Customer must remove siphon tube from the supply valve of the liquid CO2 tank to have vapor, and attach an in-line moisture trap. (sold separately)

Wheeled units should not be discharged into portable discharge hoses. Wheeled units should only be discharged into the 1/2" hose connected to the 1/2" quick connect and ball valve. The wheeled unit discharge port is supplied with a restrictor fitting.

DO NOT REMOVE RESTRICTOR FITTING.

To get maximum vacuum on your fill system, the operating input pressure may range from 60 to 80 psi for the portable console (70 to 90 for wheeled unit console). To set your regulator for the best results, take the (white) vacuum line (item #28) off the elbow connector screwed into the filler tube. Turn the on-off switch (item # 7) on and put your finger over the (yellow) vacuum line. Then, adjust the regulator up or down as needed, so that you have maximum vacuum on your gauge (item #10).

The 450 lb metal stand is pre-drilled for casters (3G0271).

Shipping Size of container and weight (freight only)

29" X 28" X 47" – 125 LBS

Warning: Operator must wear safety glasses when operating filling system equipment

DRAWING 1

ITEM NO.	PART NUMBER	DESCRIPTION	QTY.
1	1G0020	PLASTIC JAR	1
2	1G0206	FILTER CAP	1
3	1G0067	JAR FILTER	1
4	N/A	N/A	
5	1G0205	JAR GASKET	1
6	N/A	JAR BRACKET SCREWS	2
7	1G0015	VALVE 3 WAY TOGGLE	1
8	N/A	CONSOLE LID	1
9	1G0193	BULKHEAD UNION 3/8-1/4 TUBE,M20.OX1.5	1
10	1G0018	GAUGE 30" VACUUM 2" DIAL	1
11	1G0065	UNION BULKHEAD 1/2" PLASTIC	1
12	1G0207	STEM	1
13	1G0197	BULKHEAD UNION 1/4-1/4 TUBE	2

DRAWING 2

14	1G0047	TUBING POLY 1/4 YELLOW	1 ft
15	1G0198	90 ELBOW 1/4" STEM TO 1/4" TUBE	2
16	1G0199	STRAIGHT ADAPTER 1/4" TUBE -1/8" NPT	1
17	1G0201	SWIVEL SIDE TEE 1/4" TUBE TO 1/8" NPT	1
18	1G0273 (WU)	VENTURI 1/8" PC FOR Wheeled Unit	1
19	1G0041	CLAMP 2 - EAR 3/4"	2
20	1G0099	ELBOW POLY BARBED 1/2 X 1/2	1
21	1G0032	TUBING 1/2 I.D. CLEAR VINYL PER FT.	7
22	1G0200	SWIVEL TEE ADAPTER ¼" TUBE X 1/8"	1
23	1G0048	TUBING POLY 1/4 WHITE	1 ft
24	1G0046	TUBING POLY 1/4 RED	9 ft
25	1G0327	ELBOW 90 1/4 OD X 1/8 NPT	2
26	3G0082	PUSH BUTTON W/RED COVER – AIR INJECTION	1
27	1G0011	BRACKET JAR ASSEMBLY	1
28	1G0017	FILTER HOUSING ASSEMBLY	1

Please order replacement parts from:

Getz Equipment Innovators

Phone (888) 747-GETZ (4389)

Fax (309) 309-495-0625

www.getzequipment.com

DRAWING 1

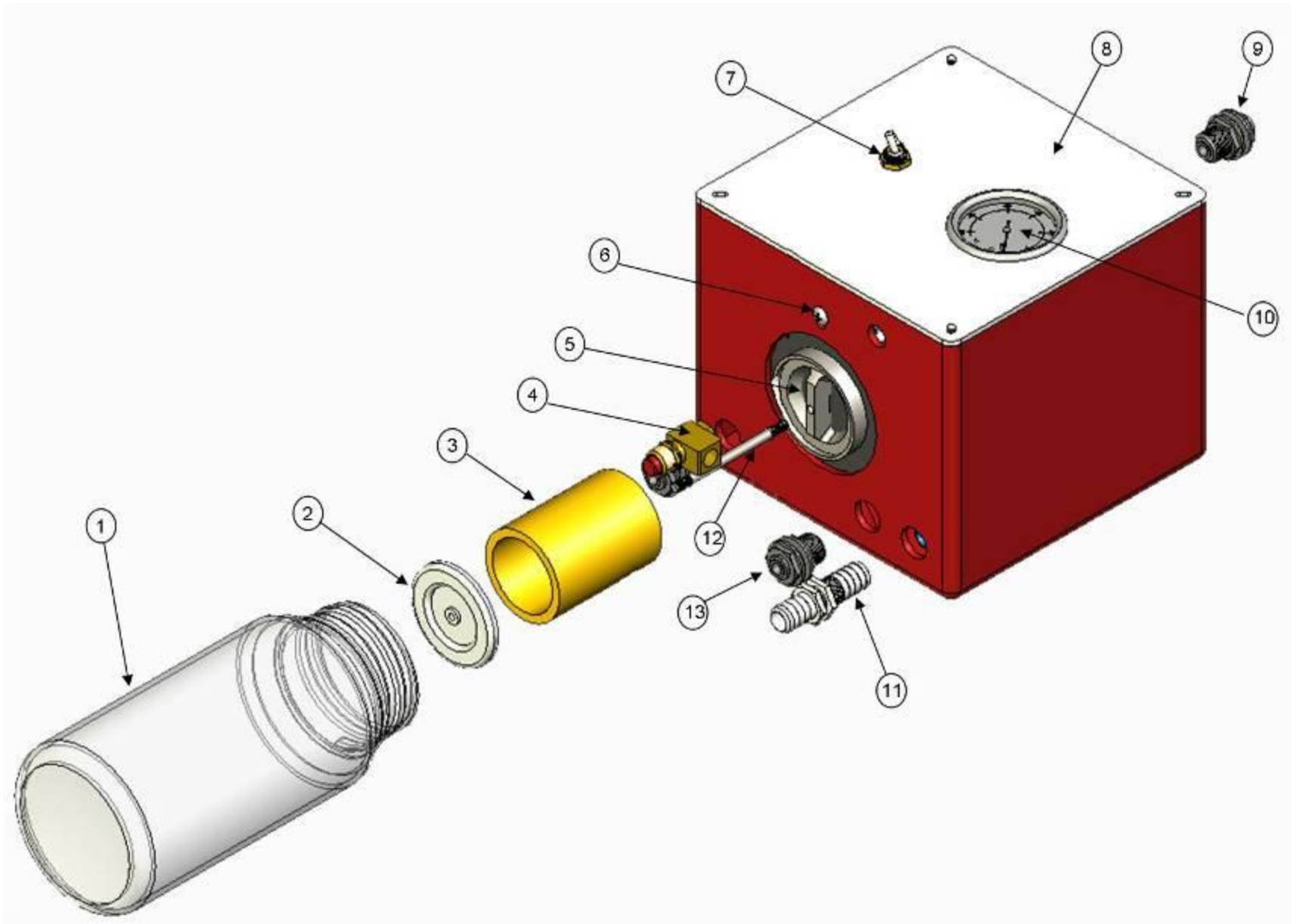

DRAWING 2 - Inside View

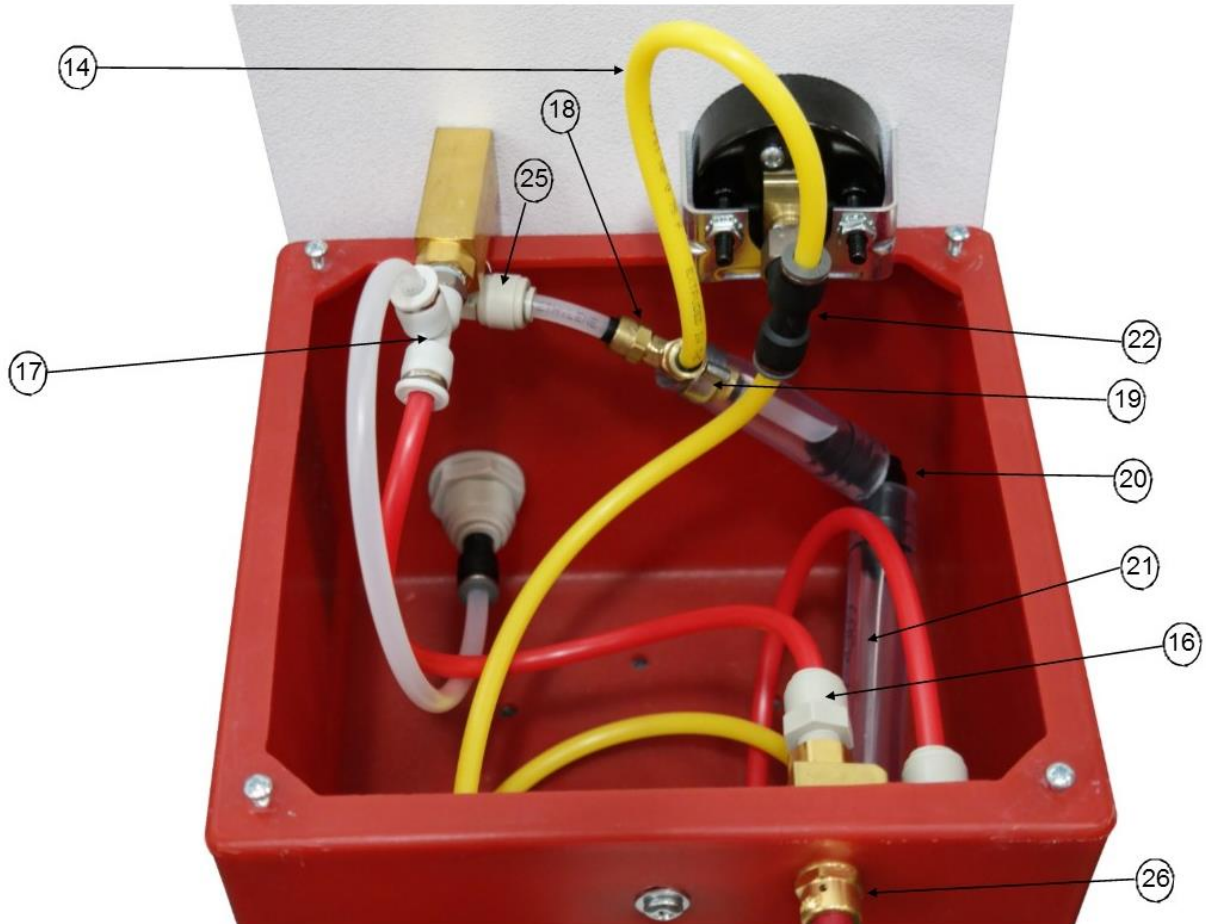
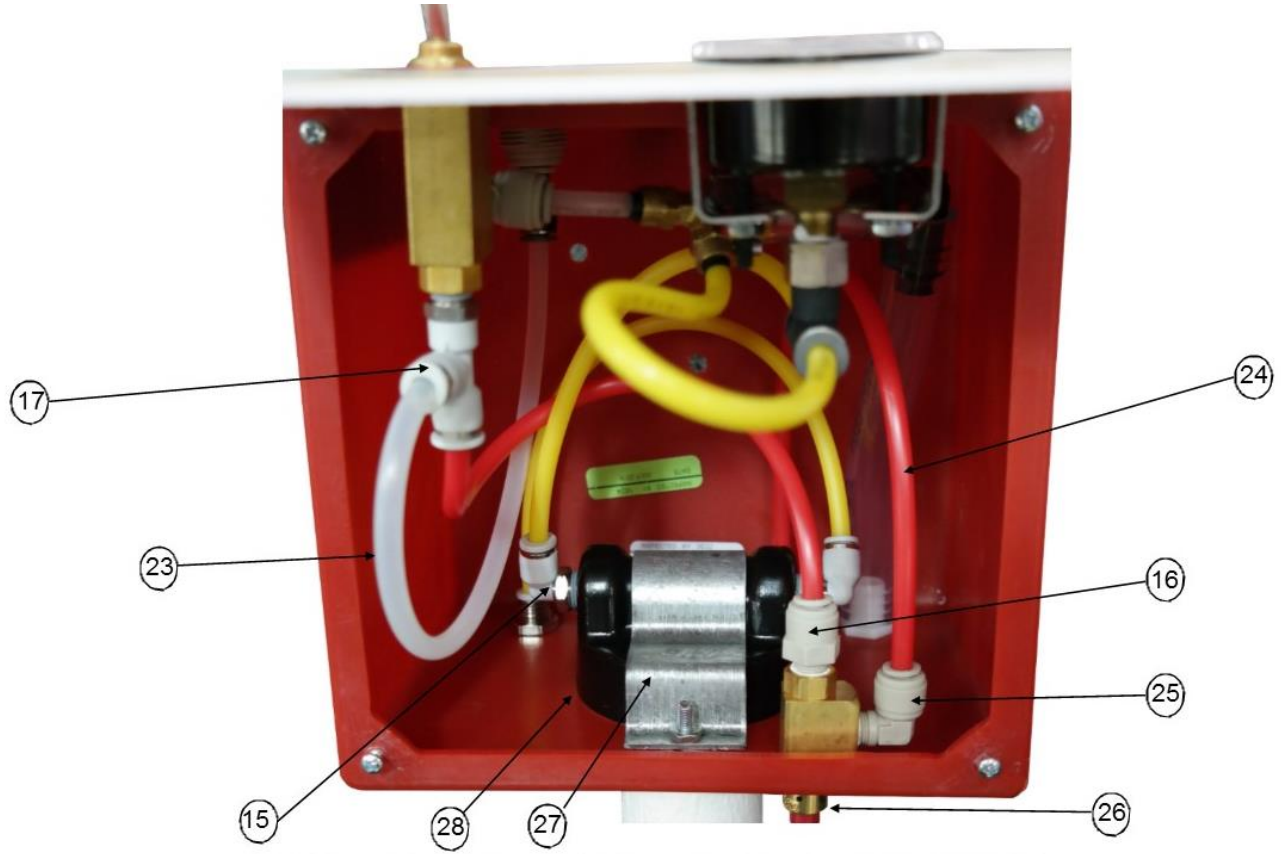

DRAWING 3

ITEM NO.	PART NUMBER	DESCRIPTION
25	1G0032	FILL LINE - TUBING 1/2 I.D. CLEAR VINYL PER FT.
26	1G0036	DISCHARGE LINE - HOSE 1/2 2000 PSI
27	1G0258	1/2 BALL VALVE - VENTED
28	1G0048	VACUUM LINE - TUBING POLY 1/4 WHITE
29	1G0091	CONE FILL TUBE RUBBER
30	3G0036	CONSOLE
31	1G0020	JAR
32	1G0325 (1G0326)	PUSH BUTTON AIR INJECTION (RED COVER)
33	1G0046	AIR INJECTION LINE - TUBING POLY 1/4 RED
34	1G0280	LID 450 HOPPER METAL
35	1G0034	LEVER LOCK RING FOR HOPPER
36	1G0250	HOPPER FILTER
37	N/A	HOPPER
38	N/A	METAL STAND
39	1G0040	COUPLING FEMALE STRAIGHT-THRU 1/2"
40	1G0287	RESTRICTOR FITTING
41	1G0235	CONE WHEELED UNIT
42	1G0118	INCOMING AIR - BULKHEAD UNION PLASTIC 3/8 TUBE TO TUBE
43	N/A	N/A
44	1G0014	RING BRACKET

Please order replacement parts from:

Getz Equipment Innovators

Phone (888) 747-GETZ (4389)

Fax (309) 309-495-0625

www.getzequipment.com

DRAWING 3



Assembly Instructions

1. Remove Filling System from shipping container
2. Remove lid and filter by releasing the band assembly and inside you will find an assortment of hoses and the console(s).
3. Remove all items from inside the hopper.
4. Separate the red stand from the hopper.
5. Attach the clear ½” vinyl tubing (item #25) to the ½” plastic Y at the base of the hopper; attach using provided worm gear clamps (item #43).
6. Place the hopper back into stand.
7. Remove the cover from the console(s) by unscrewing the (4) lid screws from the console box.
8. Mount console(s) to the stand or wall centering it above the filling system approximately 36” above the floor. Use at least two of the four mounting holes.
9. Attach the 6’ clear ½” vinyl tubing to the vent line port on the base of the console on the right side by pushing it over the hose barb. It is best if the vent line is directed to an exhaust fan.
10. Mount ring bracket (item #44) onto the stand.
11. Attach one end of the red ¼” poly tubing to the 90 degree elbow connected to the red push button valve by pushing it firmly into the connector. The push button valve is mounted to the red stand above the white ring brackets. Attach the opposite end of the red ¼” poly tubing to shop air before regulators, max 125 psi.

Caution: A moisture trap must be used to prevent moisture mixing with the dry chemical when “fluffing.”

12. Unscrew rubber cone (item #29) from filler tube. Bring filler tube and ½” clear vinyl up through the bottom of the ring bracket. Screw rubber cone back onto filler tube.
13. Attach ¼” white poly tubing (item #28) to the vacuum port on the base of the console (left side) by pushing it firmly into the connector.
14. Screw the wheeled unit discharge line (item #26) into the black bulkhead on the side of the hopper
15. Connect 3/8” white poly tubing to the fitting (item #42) on the top of the console by pushing the air line into the fitting. Attach opposite end of 3/8” tubing to air compressor or regulator. Maximum incoming air should be no more than 80 psi for regular consoles. Maximum incoming air should be no more than 90 psi for wheeled unit consoles.

Console Air Supply
with required
Moisture Filter
and Low Pressure
Regulator (60-80 PSI)



Air Injection Supply
with required Moisture
Filter (125 max PSI)

Wheeled Unit Discharge Instructions

1. Remove factory discharge hose from agent tank
2. Connect appropriate discharge adaptor
3. Connect ½” quick coupler (item #39) to adaptor
4. Connect ½” black hose to 450 hopper
5. Ensure that powder recovery lid and filter are secured with the lever lock ring (item #35) to the hopper, restrictor fitting is in place and safety relief is installed on rear of hopper
6. Discharge unit and when pressure reaches zero, disconnect discharge assembly hose

Filling Empty Wheeled Unit Instructions

*** Review Manufacturer’s manual for additional recharge/filling instructions**

1. Visually check with inspection light that empty cylinder is dry and not corroded.
2. Take clear fill line and extend it to the top of the empty cylinder to be filled.
3. Place rubber cone (item #29) into the additional wheeled unit cone (item #41) on top of cylinder neck with a clockwise ¼ turn.
4. Turn off-on valve (item #7) to “ON” position until extinguisher reaches recommended weight. Turn valve to “OFF” once it is filled. **If chemical returns to plastic jar before reaching correct weight, let it settle then turn valve back on to reach desired weight.
5. Remove fill line from cylinder neck and place in ring bracket.

Trouble Shooting for Fill System

To determine if problem is in console, take the (white) vacuum line (item #28) off of the elbow connector screwed into the filler tube. Turn the on-off switch (item # 7) on and put your finger over the (white) vacuum line (item #28). Suction should be present and gauge should read a minimum 15" of vacuum for the portables console (23" of vacuum for wheeled unit console). IF NOT, make sure jar gasket (item # 5) is in place and make sure jar is tight against gasket.

DO NOT blow air through console or jar assembly.

If there is suction at the end of the (white) vacuum line (item #28) the trouble is NOT in the console. Most problems are commonly outside the console such as: lumpy chemical, moist chemical or a plugged fill hose.

If the console is not working properly, it is recommended to replace the *venturi* (item # 18).

1. Chemical will not flow when:
 - a. Extinguisher is not vacuum tight (i.e. a cartridge extinguisher with leaky cartridge receiver).
 - b. There is a kink in a hose.
 - c. The fill line and/or vacuum line are clogged.
 - d. Jar filter assembly on console is not properly sealed (must be tight).
 - e. Air supply is not regulated and maintained at 60 – 80 PSI for portables console (70-90 for Wheeled Unit console)
2. Overflow jars located under console should never be allowed to fill more than halfway before emptying.
 - a. Filter element in jars may be blown clean with an air gun (or similar tool) weekly.
 - b. Replace filter every six months.

Recommended Maintenance

Getz Equipment Innovators has designed their plastic dry chemical fill systems to be the most maintenance-free available and to provide the longest equipment life. Nevertheless all equipment needs maintained and simple steps can be done to assure your fill system(s) continues to operate at optimum performance. To maintain optimum fill system performance we recommend the following maintenance items at a minimum. These recommendations are based on averages so frequencies may vary depending on number of extinguishers serviced using the dry chemical fill system(s).

Daily

- Empty the plastic overflow jar when dry chemical reaches the line marked on the jar. Allowing the dry chemical to go above the line on the jar will allow chemical to flow back into the console tubing causing damage to the venturi, on/off valve, and vacuum gauge.

Weekly

- Clean Hopper Lid Filter. Vacuum the inside of the filter. If there is dry chemical caked onto the filter it needs to be replaced.
 - Clean Jar Filter. Use only 10-15 psi to blow and clean the jar filter.
- Discharge Hose. Look for burn/soft spot at end by coupling and replace when worn

Annually (See Instructions Below)

- Replace Hopper Lid Filter
 - Replace Jar Filter
 - Replace Jar Gasket
 - Replace Venturi

Maintenance Kit Instructions

100/150 lb Dry Chemical Fill Systems (Portables) Console 3G0089

1G0024 - Hopper Lid Filter (See Drawing #3)

1. Unlatch the hopper lever lock ring (35) and remove with the plastic hopper lid (34).
2. Remove old hopper lid filter (36) and discard.
3. Install new hopper lid filter and reinstall plastic hopper lid (beveled edge on top) and lever lock ring.

1G0067 – Jar Filter & 1G00205 – Jar Gasket (See Drawing #1)

4. Unscrew the Plastic Jar (1) counterclockwise from the bottom of the console and the metal Filter Cap (2). The Jar Filter (3) should be loose to remove after the metal Filter Cap is removed.
5. Remove the old Jar Gasket (5). Gently clean the Filter Housing Assembly (28) being careful not to blow air up into the Housing/Console that will force chemical into the tubing.
6. Install the new Jar Gasket and new Jar Filter with the metal Filter Cap. Install the Plastic Jar.

1G0273 – Venturi (See Drawing Below)

1. Remove the four corner screws on the front console lid to access the inside.
2. Remove vent line (5) from the poly elbow (6).
3. Use a 7/16” open end wrench to remove the two brass nuts at (1) and (2) and pull the clear and yellow ¼” tubing with those brass nuts from the venturi (4).
4. Unscrew (counterclockwise) the brass nut (3) using the ear clamp. This will leave the nut (3) in the vent tube (5) and the piece of ¼” clear plastic tube.
5. Remove the brass nut on the new venturi that has the piece of ¼” clear plastic tubing. The ¼” clear plastic tubing can be removed from the new venturi if the same tubing stayed in the vent tube (5).
6. Install the new venturi into the brass nut (3) that was left in the vent tube (5).
7. Remove the other two brass nuts in the new venturi.
8. Insert ¼” clear and yellow tubing and tighten brass nuts (1) and (2).
9. Insert vent line (5) into the poly elbow (6).
10. Replace front Console lid and tighten four corner screws.

